



POWERSPORTS

OWNER'S MANUAL



Model DB70

Always wear a Helmet, it could save your life!

Provincial / Municipal governments have different regulations pertaining to owning and operating an off-road vehicle, learn the regulations in your area.

(888) 405-8725 Coleman Powersports
364 S Smith Rd. Tempe, AZ. 85281

www.colemanpowered.com

REV# 042115

To the Owner

Congratulations on your purchase of a Coleman Powersports Dirt Bike. This Owner's/Operator's manual will provide information regarding safe operation, operational instructions, maintenance and care. Fully understanding this manual and following all of the instructions herein will provide the knowledge needed to have safe and enjoyable Dirt Bike operation.

For questions regarding operation and maintenance of this Dirt Bike, please call Coleman Powersports toll free 888-405-8725 or go to colemanpowered.com

Safety - Notice to parents

Children differ in skills, physical abilities, and judgement. Some children may not be able to operate a Dirt Bike safely. Parents should supervise their child's use of the Dirt Bike at all times. Parents should permit continued use only if they determine that the child has the ability to operate the Dirt Bike safely.

THIS DIRT BIKE IS NOT A TOY AND COULD BE HAZARDOUS TO OPERATE.

Reading the Owner's/ Operator's Manual

It is important this manual is read from cover to cover carefully by the Dirt Bike owner and all operators. Parents should review the manual carefully with their children. Never allow anyone to operate the Dirt Bike without first reading and understanding the Owner's/Operator's manual.

This Owner's/ Operator's manual should be a permanent part of the Dirt Bike and should remain with the vehicle at all times. The manual should also remain with the vehicle if sold.

This manual is based on the latest product information available at the time of publication. Coleman Powersports has a policy of continually improving its products. Due to improvements, or other changes, there may be some discrepancies. We reserve the right to make product changes at any time, without notice and without incurring any obligation to make the same or similar changes to vehicles previously built or sold.

⚠ WARNING

The engine exhaust from this Dirt Bike contains chemicals known to the state of California to cause cancer, birth defects or other reproductive harm.

TABLE OF CONTENTS

COLEMAN POWERSPORTS		
WARRANTY.....	2	
IMPORTANT SAFETY AND NOTATION		
INFORMATION.....	4	
LABEL LOCATIONS.....	5	
WARNING LABELS.....	6	
SAFETY	7	
DESCRIPTION AND PART LOCATIONS.	8	
DESCRIPTION AND PART FUNCTIONS.	9	
RIGHT HAND BRAKE LEVER.....	9	
RIGHT THROTTLE GRIP.....	9	
ENGINE STOP SWITCH.....	9	
ELECTRIC START BUTTON.....	9	
FOOTBRAKE LEVER.....	10	
IGNITION KEY.....	10	
CHOKE LEVER.....	10	
FUEL VALVE.....	11	
FUEL CAP.....	11	
FUEL AND OIL.....	12	
FUEL.....	12	
ENGINE OIL.....	12	
BREAK IN.....	13	
PRE RIDE INSPECTION.....	14	
RIDING DIRT BIKE.....	15	
HELMET, EYE PROTECTION AND		
PROTECTIVE CLOTHING.....	15	
STARTING THE ENGINE.....	16	
LOAD GUIDELINES.....	18	
AFTER MARKET PARTS.....	18	
MAINTENANCE.....	19	
MAINTENANCE CHART.....	20	
AIR FILTER.....	20	
SPARK PLUG.....	22	
ENGINE OIL	23	
CHECKING.....	23	
CHANGING.....	23	
IDLE SPEED ADJUSTMENT.....	24	
THROTTLE CABLE ADJUSTMENT.....	24	
BRAKES.....	25	
FRONT BRAKE , HAND LEVER.	25	
REAR BRAKE., FOOT LEVER...	25	
FUEL HOSE INSPECTION.....	26	
VALVE CLEARANCE.....	26	
CHAIN AND SPROCKET INSP.....	27	
INSPECTION.....	27	
TENSION AND ADJUSTMENT.....	27	
CLEANING AND LUBRICATION..	27	
TIRES.....	28	
TIRE PRESSURES.....	28	
TIRE SIZE.....	28	
REPLACING.....	28	
STORAGE.....	29	
WASHING THE DIRT BIKE.....	30	
TRANSPORTING.....	30	
TROUBLE SHOOTING.....	31	
SPECIFICATIONS.....	32	
ELECTRIC DIAGRAM.....	33	
FRAME AND ENGINE NUMBER		
LOCATION.....	34	
EMISSION CONTROL SYSTEM		
WARRANTY.....	35	

COLEMAN POWERSPORTS LIMITED WARRANTY

This Warranty is NOT the Emissions Control Warranty

Please note this is a general Limited Warranty for this product. It IS NOT an Emissions Control Warranty. Please see the Emissions Control Warranty in this manual for warranties covering Emission components. The Emissions Control Warranty can be found on page 35.

The Warranty

Coleman Powersports offers the following warranty to the initial purchaser of this new Coleman Powersports product. The initial purchaser is defined as the first person to purchase a new Coleman Powersports product from an Authorized Retailer of Coleman Powersports products.

The limited warranty period for this product is 90 days from the date of purchase shown on the original sales receipt.

What is a Defect?

The Product is warranted to be free from manufacturing defects in material and workmanship for a period of 90 days from the date of purchase shown on the sales receipt. During this period of time Coleman Powersports will, at its option, either repair or replace any original Coleman Powersports part which is covered by this warranty and is proven to be defective in workmanship or material.

To qualify for this warranty the part:

1. Must have been purchase from Coleman Powersports or from an authorized Coleman Powersports Retailer.
2. This warranty does not apply to any vehicle which is used in competition or used in a manner not consistent with the normal and proper intended use for the vehicle. This vehicle is not intended for rental or commercial use.

Who Can Perform Repairs Under this Warranty?

Repairs under this warranty should be performed by an authorized Coleman Powersports retailer or comparable servicing dealer.

How to get service under this warranty

To get warranty service call Coleman Powersports at 888-405-8725 for the location of your local servicing retailer / dealer. Please do not return the product to the retailer where the product was purchased unless instructed to do so by Coleman Powersports. The retailer of this product does not make any warranty of its own and has no authority to implement this warranty on behalf of Coleman Powersports without the approval of Coleman Powersports. **A COPY OF YOUR SALES RECEIPT IS REQUIRED FOR WARRANTY SERVICE.**

What this Warranty Does Not Cover

This warranty does not cover the following

- 1. Damage due to lack or improper maintenance as described in this manual.**
- 2. Damage which is caused by normal use and not caused by a defect in materials or workmanship.**
- 3. Use of the product which is not consistent with the intended use as described in the operating instructions.**
- 4. Any expendable maintenance item which need replacement or service as part of normal maintenance, unless such items have defects in material or workmanship which cause failure or premature wear.**
- 5. Any product which has been altered or modified in a manner not consistent with the original design of the product or in a manner not approved by Coleman Powersports.**
- 7. Damage or failures due to abuse, neglect, or misuse of the product.**

Limitations of this Warranty

This warranty does not cover and Coleman Powersports disclaims any responsibility for:

- 1. Loss of time or loss of use of the product.**
- 2. Transportation costs to and from the authorized service center.**
- 3. Other loss or damage to other equipment or personal items.**

Length of Implied Warranties

Any implied warranties are limited to the duration set forth in this warranty. Coleman Powersports does not make any claim as to the merchantability or fitness for a particular purpose which would extend longer than the duration of this written warranty.

Check you State Laws as some State Laws do not allow limitations as to the duration of an implied warranty. Some States may also not allow limitation or exclusions based on incidental or consequential damages.

Important Safety and Notation Info

To emphasize special important information in the manual, please note the following :



This is the alert symbol. The symbol means **ATTENTION!, BE-COME ALERT!**,

To emphasize important safety information, the word **WARNING**, with the alert symbol, has special meaning.:



Indicates a potential hazard that could result in **SEVERE INJURY** or **DEATH** to the operator, bystander

To emphasize important information, the word **CAUTION** has special meaning.:

CAUTION:

Indicates special precautions that must be taken to avoid damage to the Dirt Bike.

To emphasize important information, the word **NOTE** has special meaning.:

NOTE:

Indicates key information to make procedures easier or clearer to understand.

WARNING or **CAUTION**

The first part will identify a **POTENTIAL HAZARD**.

The second part will describe **WHAT COULD HAPPEN** if the warning or caution is ignored.

The third part will describe **HOW TO AVOID THE HAZARD**.

Coleman Powersports is concerned about the environment and believes in conserving and protecting all natural resources. For this reason , owners should recycle, trade in, or dispose as appropriate, batteries, oil and tires.

This manual is based on the latest product information available at the time of publication. Coleman Powersports has a policy of continually improving its products. Due to improvements, or other changes, there may be some discrepancies. We reserve the right to make product changes at any time, without notice and without incurring any obligation to make the same or similar changes to vehicles previously built or sold.

IMPORTANT LABELS

LOCATION



Warning Labels

1

WARNING

- Study and understand the owner's manual before operating this Dirt Bike.
- Always wear a DOT certified motorcycle helmet, protective riding gear and eye protection.
- Never operate this Dirt Bike while under the influence of drugs or alcohol.

2

WARNING

Check the tires before operating to insure the proper tire pressure. Improperly inflated tires can lead to loss of control which could result in injury or death.

Cold tire pressure:

Front: 28psi \pm .5psi (200 \pm 3.5kpa)

Rear: 32psi \pm .5psi (225 \pm 3.5kpa)

Maximum weight capacity is

165lbs. (75 kg)

3

WARNING

No one under the age of 16 should operate this dirt bike without adult supervision

SAFETY

All operators under the age of 16 should be supervised continually by an adult. Some children, even though they may be the correct age to operate a Dirt Bike, may not have the coordination or ability to do so safely. It is the parents responsibility to access the childs abilities before allowing the child to continue to ride.

Always wear a certified DOT or SNELL motorcycle type helmet that fits properly, over the ankle boots, eye protection, gloves, long sleeve shirt and long pants while operating this Dirt Bike.

Never allow a passenger on this Dirt Bike. This Dirt Bike is designed for one operator and no passengers.

Never operate this Dirt Bike on paved surfaces and/or public roads. Pavement may cause the Dirt Bike to become unstable.

Always go slowly and pay attention to unfamiliar terrain. Be alert to changing terrain conditions when operating the Dirt Bike.

Never take drugs or alcohol before or during operating this Dirt Bike.

Never traverse, climb or go down a hill that is too steep. Avoid hills with loose or slippery terrain.

Never attempt wheelies, jumps or any other type of stunts on this Dirt Bike.

Always follow the pre-ride inspection procedures and maintenance procedures located in this manual before use.

Always go slow on terrain that is not familiar, be alert, an obstacle could come up unexpectedly.

Always keep both hands on the handlebars and both feet on the footpegs, doing so will help the operator be ready for unexpected situations.

Never operate this Dirt Bike at night. Night is defined as 30 minutes before sunrise and 30 minutes after sunset.

DESCRIPTIONS AND PART LOCATIONS



1. Front Wheel
2. Front Brake Drum
3. Front Fender
4. Front Forks/
Shocks
5. Fuel tank cap
6. Fuel tank
7. Seat
8. Rear Fender
9. Rear Wheel
10. Rear sprocket
11. Drive Chain
12. Kick Stand
13. Ignition Key
14. Choke lever
15. Fuel Valve



16. Rear Wheel
17. Muffler
18. Rear Fender
19. Carburetor
20. Spark Plug
21. Foot Brake lever
22. Oil fill plug
23. Rear Mono Shock
24. Rear brake
adjustment
25. Left hand grip
26. Front brake lever
27. Right throttle hand
grip
28. ON/OFF switch

DESCRIPTION AND PART FUNCTIONS

Right side handlebar functions

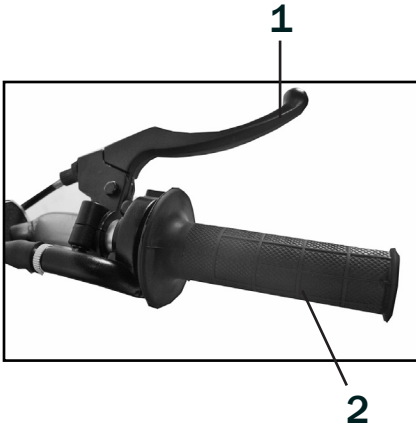



Right hand brake lever (1). Front brakes are applied when the right hand brake lever is pulled toward the hand grip.

Right Throttle Grip (2): The engine speed is regulated by the position of the right throttle grip. Throttle is increased by turning the throttle grip toward the operator. Engine speed is decreased by turning the throttle grip away from the operator.

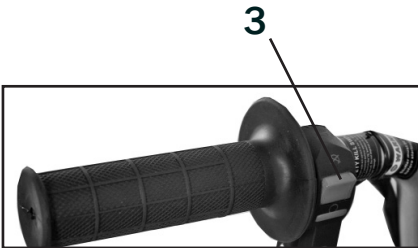
Left side handlebar functions



Engine Stop Switch (3): Dirt Bike engine can start when the Engine stop switch is placed in the  (on) position. Engine will shut off and the engine will not start when the switch is placed in the  (off) position.

Note: The key switch located on the side of the dirt bike needs to be placed in the (on) position for the engine to start.

DESCRIPTION AND PART FUNCTIONS

Foot brake lever

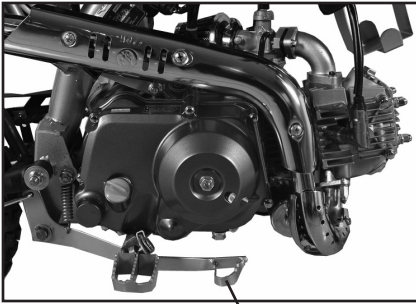

Foot brake lever (1): To activate the rear brake, depress the foot brake lever.

1

Ignition Key



Ignition Key (2)

Engine can start once the ignition key is placed in the (on) position.

Note: Engine stop switch located on the handlebars also needs to be placed in the (on) position for the engine to start.

2

Choke Lever



Choke Lever (1): If the engine is cold, the choke can help start the engine by lifting the choke lever to the "ON" (up) position. Once engine has warmed up, place choke lever to the "OFF" (down) position.

3

DESCRIPTION AND PART FUNCTIONS

Fuel Valve operation

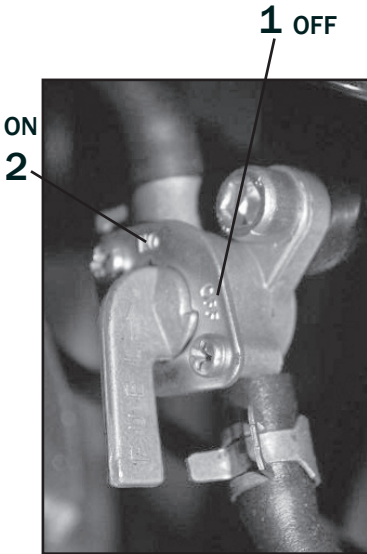

Fuel Valve The fuel valve has 2 positions: “OFF”, “ON”

(OFF) position (1): Fuel will not flow to the carburetor in this position. Always turn the fuel valve to the “OFF” position when unit is not in use or is being transported.

(ON) position (2) This is the normal operating position. The “ON” position allows fuel to flow from the fuel valve to the carburetor. Turn the fuel valve to the “ON” position when ready to start and ride your Dirt Bike.

Fuel Cap



Fuel Tank Cap

To open the fuel tank cap (4). Turn the cap counter clockwise. To re-install the cap, turn the cap clockwise until snug. Make sure the vent tube is attached and the cap is seated properly .

FUEL AND OIL

FUEL

Never use leaded gasoline in this product. It could affect the engine's emissions and damage the engine. Dirt bike requires clean unleaded regular gasoline with a minimum octane rating of 87 or higher.

Gasoline/ Ethanol blends

A blend of unleaded gasoline with Ethanol, also known as GASOHOL, at or below 10% (E10) can be used in your Dirt Bike. Ethanol greater than 10% can damage your engine and will void your warranty.

Gasoline/Methanol Blends

A blend of gasoline with Methanol of 5% or less can be used in your Dirt Bike. Do not use gasoline, under any circumstances, containing more than 5% Methanol, doing so will damage your engine and will void the warranty.

Fuel Filling

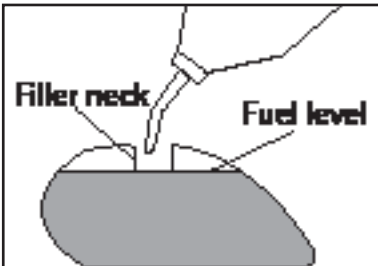

⚠ WARNING

Overfilling the fuel tank can cause the fuel to expand which can cause overflow due to the heat from the engine or sun. Spilled fuel can catch fire.

Never fill the fuel tank above the bottom edge of the filler neck.

⚠ WARNING

Fuel and fuel vapor are highly flammable and toxic. You can be burned or poisoned while refueling.

Before refueling make sure to follow the procedures listed:

- 1 Shut off engine, Make sure there are no flames, sparks or heat sources close by.
- 2 Refuel only outdoors in a well ventilated area.
- 3 Do not smoke while refueling.
- 4 Wipe up any spills immediately.
- 5 Avoid breathing any fuel vapors.
- 6 Keep children and pets away.

ENGINE OIL

The recommended oil for this Dirt Bike is SAE15W-40 motor oil, if this oil is not available, any of the oils on the chart below will work. Note the temperature requirements for each of the oils.

Quantity of oil - 1qt. (.9L).

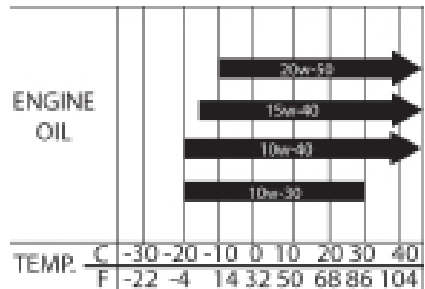

BREAK - IN

Break in period

The initial 5 hours of operation is most important in the life of your Dirt Bike. Proper operation during this break in period will help assure maximum life of your Dirt Bike engine.

The following guidelines will explain the proper break in procedures.

1. During the first 5 hours of operation, do not apply more than 1/2 throttle.
2. During the next 5 hours of operation do not apply more the 3/4 throttle

Vary the engine speed:

Make sure to vary the engine speed during the break in period, this allows the engine to load and unload which helps the parts to seat properly. It is essential to place some stress on the engine during the break in process, however, too much stress could cause damage to the engine components. Be careful not to load the engine too much.

Allow oil to circulate before riding.

Allow the Dirt Bike engine to warm up before riding. This allows the oil to circulate throughout the engine which lubricates the components.

Observe your initial and most critical maintenance service

The initial service(break in maintenance) is the most important service for your Dirt Bike. During the break-in time frame, all of the engine components will have mated together and seated. Maintenance required as part of the initial service includes correction of all adjustments, tightening of all fasteners and replacement of dirty oil. Timely performance of this maintenance will help make sure your Dirt Bike will have the best service life and performance of the engine.

PRE-RIDE INSPECTION

Inspecting and checking the condition of the Dirt Bike before each ride is important. Following the pre-ride check list will help insure the you do not have mechanical problems which could result in injury or becoming stranded. Make sure the Dirt Bike is in good operating condition before each ride.

WARNING

Failing to inspect and maintain your Dirt Bike could be hazardous.

Not following the pre-ride inspection procedures could result in losing control of the Dirt Bike resulting in an accident or damage to the Dirt Bike

Always perform a Pre-ride inspection before each ride.

WARNING

Performing maintenance and checks while the engine is running could be hazardous.

You could be severely injured by moving parts or hot surfaces.

Never perform maintenance or check procedures while the engine is running with the exception of checking the engine stop switch or throttle.

WHAT TO CHECK	CHECK FOR
Steering	<ul style="list-style-type: none"> • Smoothness • No restriction of movement
Brakes	<ul style="list-style-type: none"> • Proper operation and free-play.
Tires	<ul style="list-style-type: none"> • Proper tire pressure • Proper tread depth • Rubber has no cracks
Fuel Tank	<ul style="list-style-type: none"> • Enough fuel for the ride • Fuel cap secure • Hoses have no signs of cracks or leaks
Hand Grip Throttle	<ul style="list-style-type: none"> • Hand grip throttle snaps back to idle when released • Operates freely • Has correct free-play
Engine Stop Switch	<ul style="list-style-type: none"> • Switch shuts off engine when activated.
Engine Oil	<ul style="list-style-type: none"> • Correct oil level
Drive Chain	<ul style="list-style-type: none"> • Proper tension • Lubricated • No excessive wear or damage
General Condition	<ul style="list-style-type: none"> • All nuts and bolts tight • No rattles from engine or frame while running

RIDING THE DIRT BIKE

HELMET, EYE PROTECTION, PROTECTIVE CLOTHING

Always wear a DOT or SNELL certified motorcycle helmet (1). A helmet helps protect against serious head injuries in the event of an accident. A helmet is the most important safety gear item you can wear. Consult with a motorcycle dealer for the correct size and type of motorcycle helmet that is right for you.

Always wear eye protection when riding a Dirt Bike such as a face shield or goggles (2). While riding a Dirt Bike you can be hit in the eyes by any of the following: dust, branches, rocks, debris from other riders, bugs, etc. Good eye protection as well as a helmet and protective riding gear should be mandatory when riding an Dirt Bike.

Wear protective clothing: Long sleeve shirt (3), Gloves (4), Long pants (5), over the ankle boots (6). Riding a Dirt bike exposes the rider to many hazards, wearing protective clothing can help protect the rider from injury.

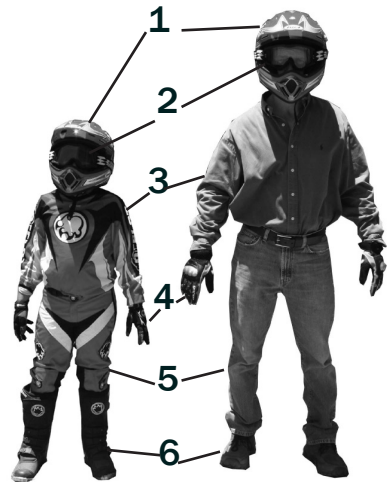

⚠ WARNING

Riding a Dirt Bike without a helmet, eye protection, and protective clothing can be hazardous

Riding a Dirt Bike without a helmet increases the chance of severe head injury or death in the event of an accident.

Riding a Dirt Bike without eye protection such as a face shield or goggles could result in severe injury in the event of an accident.

Riding a Dirt Bike without protective clothing; over the ankle boots, long pants, gloves, long sleeve shirt could result in severe injury in the event of an accident.

Always wear a Helmet, eye protection, long pants, long sleeve shirt, over the ankle boots and gloves when riding a Dirt Bike

RIDING THE DIRT BIKE

STARTING ENGINE

To start the engine

1. Before attempting to start the engine, make sure to follow the pre-ride inspection checklist in this manual.
2. Place the fuel valve (1) to the "ON" position.
3. Turn the ignition key (2) to the "ON" position.
4. Place the ON/OFF switch (3) located on the handlebars to the (ON) position
5. If engine is cold, place the choke lever (4) in the up position.
Note: If the engine is already warm the choke will not be needed.
6. Start the engine by depressing the start button located on the handlebars(5)
7. Once engine has warmed up for a few minutes, place the choke lever (4) back to the down position.

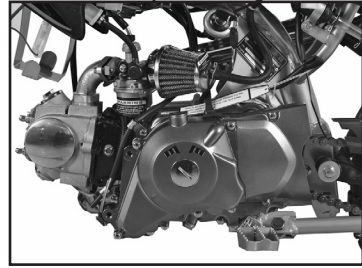
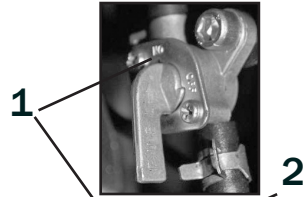

⚠ WARNING

Starting or running the Dirt Bike in an enclosed area such as a garage or shed where there is no ventilation is hazardous.

Inhaling exhaust fumes from the Dirt Bike can cause severe injury or death.

Never start or run the Dirt Bike in an inclosed environment where there is no ventilation. Always start and run outdoors.

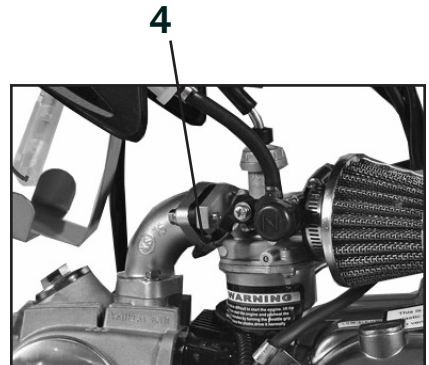

RIDING THE DIRT BIKE

WARNING

Operating this Dirt Bike at excessive speeds could be hazardous.

Riding at excessive speeds increases your chances of losing control of the Dirt Bike, which could result in severe injury or death.

Always go at a speed that is proper for the terrain, visibility, operating conditions, operator skill, and operator experience. Always know the terrain before riding.

WARNING

Removing hands from the handlebars and/or feet from the footrest while operating the Dirt Bike could be hazardous.

Removing both or one hand from the handlebars and/or feet from the footrests could result in loss of control of the Dirt Bike resulting in severe injury or death.

Always ride with both hands on the handlebars and both feet on the footrests while operating the Dirt Bike.

WARNING

Applying full throttle when starting off could be hazardous.

The Dirt Bike could lurch forward causing the front wheels to leave the ground causing loss of control.

Always open the throttle gradually when taking off from a stopped position.

RIDING THE DIRT BIKE

Load Guidelines

Load guidelines including accessories:

Never exceed the maximum load capability of the Dirt Bike. This includes the weight of the rider and any cargo. This Dirt Bike is rated at 165lbs. (75kg).

If the Dirt Bike has cargo racks, do not exceed the recommended weight limits for the racks. Make sure all cargo is secure as well as the connection points on the rack. Distribute the weight of cargo evenly and low so the center of gravity is not adversely affected.

Do not add any accessory or cargo to the handlebars that could impede vision or make the Dirt Bike harder to steer.

Make sure accessories do not get in the way of any controls of the Dirt Bike.

Only carry cargo that is not bulky or too heavy.

Make sure all cargo is held securely in place, loose cargo can become a hazard.

While carrying cargo, go slow. Cargo can adversely affect handling at higher speeds

Allow plenty of distance to stop while carrying cargo, The more weight on the Dirt Bike, the longer distance it will take to stop.

After Market parts

After market parts and accessories are available from many manufacturers. Coleman Powersports cannot confirm the quality, safety or suitability of all the accessories available. When purchasing an accessory, use caution, the handling of the Dirt Bike could become affected. Some accessories may make the Dirt Bike unsafe to ride. If you have a question about a modification or accessory, contact your dealer or call Coleman Powersports



WARNING

Riding this Dirt Bike with modifications or adding accessories could be hazardous.

Modifications to the Dirt Bike, including adding accessories, could adversely affect the handling of the Dirt Bike causing an accident which could result in severe injury or death.

Never Modify this Dirt Bike in anyway, including adding accessories, unless the modification is a genuine certified modification or accessory approved by the manufacture. Never modify the Dirt Bike with improper installation. Make sure to follow all instructions recommended in the certified modification. Use only genuine parts. For questions, contact your dealer.

MAINTENANCE

For maintenance, your Dirt Bike may be maintained by an authorized Coleman Powersports service dealer or a repair shop of your choosing.

Following the proper maintenance procedures and time table for maintenance listed in this manual is important for the safety of the rider and the life span of the Dirt Bike. When riding in harsh conditions, such as water, mud and dust, the maintenance procedures should be performed more often.

WARNING

Failing to perform the recommended maintenance on this Dirt Bike could be hazardous.

Failing to perform proper maintenance on this Dirt Bike could result in an accident.

Always perform the recommended maintenance for the Dirt Bike as listed in this manual.

WARNING

Performing maintenance and inspection while the engine is running could be hazardous.

Performing maintenance and inspections while the engine is running could result in getting body parts or clothing caught in moving parts, or could result in touching hot items which could result in severe injury.

Shut off engine when performing maintenance and inspection checks, with the exception checking the engine stop switch and throttle.

CAUTION

Failing to perform recommended maintenance on this Dirt Bike could damage the Dirt Bike engine and components

Always perform the recommended maintenance on this Dirt Bike as listed in this manual.

Maintenance will need to be performed more often if ridden in wet, muddy or dusty conditions.

CAUTION

Failing to use compatible parts with the original replacement parts could damage Dirt Bike.

Using parts that are of low quality could result in Dirt Bike breakdowns and reduce the useful life of the Dirt Bike.

Never use parts that are not compatible with the original parts.

MAINTENANCE

ITEM	First 5 hours of operation	First 20 hours of operation or 1 month	Every 50 hours or 3 months	Every 100 hours or 6 months
Exhaust pipe nuts and muffler bolts	T	T	T	
Air cleaner element	I	I	I	
Valve Clearance**		I		I
Spark Plug		I	I	R
Fuel Line		I	I	
Idle speed		I	I	
Throttle cable play		I	I	
Engine oil	R		R	
Drive Chain	Inspect drive chain before each ride. Clean and lubricate as necessary			
Brakes	I	I	I	
Brake cables	I	I	I	
Brake lever free play	I	I	I	
Tires	I	I	I	
Steering	I	I	I	
Front suspension	I	I	I	
Rear suspension	I	I	I	
Chassis nuts and bolts	T	T	T	

** Recommended to be performed by an authorized service center or service center of the owner's choosing.

NOTE: I = INSPECT AND CLEAN, ADJUST, REPLACE OR LUBRICATE AS NECESSARY, R=REPLACE, T = TIGHTEN

MAINTENANCE

Air Filter

The air cleaner element needs to be cleaned or replaced periodically (see chart for cleaning/replace-ment intervals). The air filter element will need to be cleaned more often if Dirt Bike is ridden in muddy, wet, or dusty conditions. A clean air filter will help the Dirt Bike run at peak performance allowing better gas mileage, more power and will protect the engine from the damaging effects of dirt entering the engine.

CAUTION

Clean air filter frequently if Dirt Bike is driven in wet, muddy or dusty conditions.

Driving in the above conditions without cleaning frequently can plug up the air filter which can cause poor gas mileage, low power and cause damage to the engine.

Air filter removal, inspection and cleaning instructions

1. Locate air filter (1) attached to the carburetor.
2. Remove filter by loosening clamp (2) which holds the Air filter to the carburetor.
3. Remove the Air filter (2) and inspect. If filter is damaged or is saturated with debris beyond cleaning, replace.
4. To clean Air filter, tap gently on a hard surface to loosen and remove dirt and debris. Use compressed air to blow from the inside out any excess debris. Note: Be careful not to use too high of air pressure while blowing out the air filter. Too much air pressure could damage filter.
5. Re-install air filter to carburetor

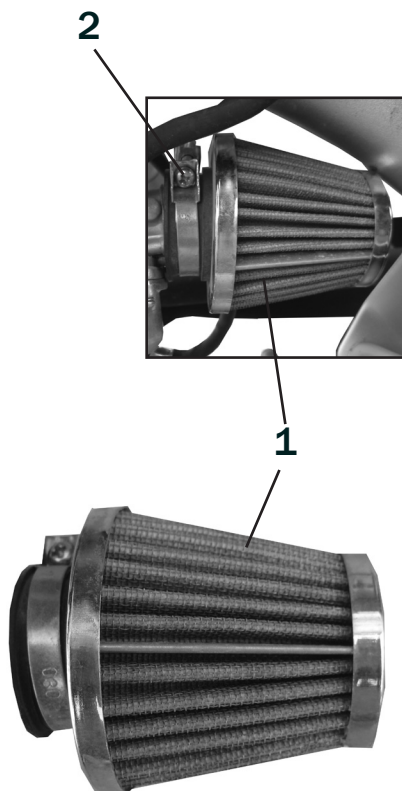

MAINTENANCE

Spark Plug

This Dirt Bike comes equipped with an NGK C7HSA spark plug.

To inspect the spark plug, remove the plug cap (1) then remove the spark plug from the engine with the spark plug tool provided.

Inspect the plug for carbon deposits and clean if necessary. If plug shows excessive carbon, replace the plug.

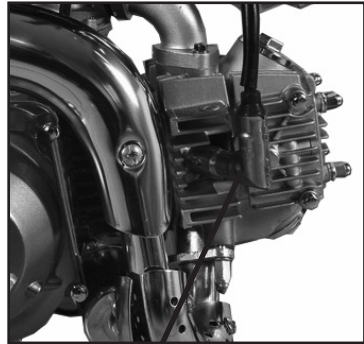

1

CAUTION

Dirt can damage the engine if it enters the spark plug hole.

Make sure the spark plug hole is covered after removing plug.

Use a thickness feeler to inspect the spark plug gap (2). The spark plug gap should be 0.6 - 0.8mm (0.024 - 0.032 in.)

Re-install the inspected plug or new plug until finger tight. Finish tightening plug with a wrench. If the plug is a new plug, tighten approximately 1/2 turn more with the wrench. If plug is an old plug, tighten approximately 1/8 turn more with a wrench.

NGK C7HSA

0.6 - 0.8 mm
(0.024 - 0.032 in.)



2

MAINTENANCE

Engine Oil

The proper amount and grade of engine oil will have a great impact on the life of the engine. Checking the oil daily and changing the oil as listed in the maintenance schedule is the most important maintenance procedure there is for the engine.

Checking the engine oil

1. Make sure the Dirt Bike is on level ground
2. Check engine oil level by removing the Oil Plug (dip stick) (1) and checking the oil level.
3. If engine oil is low (L), add oil until oil is at the Full mark (H) on the dip stick. Use the correct grade of oil as listed in this manual. Do not over or under fill engine with oil, this could damage the engine.

Changing the engine oil

1. Make sure engine is warm before attempting to drain the oil. A warm engine will help the oil drain quicker.
2. Remove the oil fill plug (Dip stick) (1)
3. Remove the drain bolt (2) located on the bottom of the engine.
4. Allow the oil to drain in an appropriate container. Note: Dispose of oil at an oil recycle center.
5. Install the drain plug and fill with the appropriate type of oil as listed in this manual. This Dirt Bike takes 1qt. (.9L) of engine oil.
6. Re-install fill cap, Start engine and allow to run for a few minutes, Re-check oil level and fill accordingly.

⚠ WARNING

New and used oil can be hazardous

Children and pets can be harmed by swallowing new or used oil. Continuous contact with used engine oil has been found to cause skin cancer in laboratory animals

Always keep new or used oil away from children and pets.

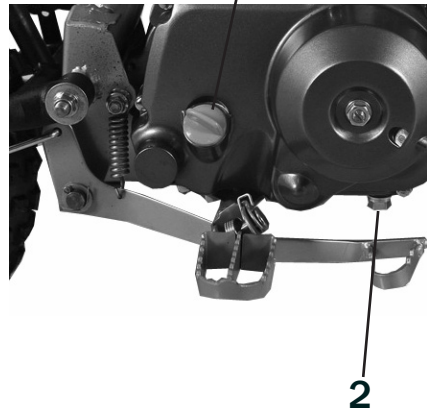

MAINTENANCE

Idle speed adjustment

The idle speed should be set at 1500 ± 150 RPMs

To adjust the idle speed:

1. locate the idle adjustment screw (1) located on the carburetor.
2. Allow the engine to warm up approximately 10 minutes
3. With the engine running, turn the idle adjustment screw in or out at small increments until the correct idle is achieved.

Note: A service center can perform this adjustment . A diagnostic tachometer is required for this adjustment.

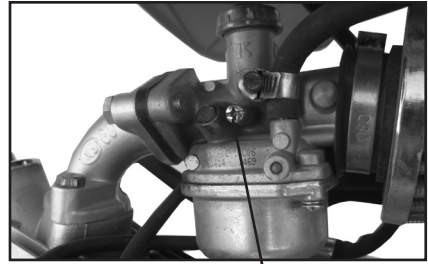

1

Throttle Cable adjustment

It is important that the throttle grip have a certain amount of free play so the throttle does not rise when the handlebars are turned from left to right.

The hand grip throttle free play (2) should be $.078 - .24$ in (2-6 mm)

To adjust freeplay

1. Loosen jam nut (3)
2. Turn adjusting nut (4) to proper setting
3. Once throttle grip is at the proper freeplay, re-tighten the jam nut (3).

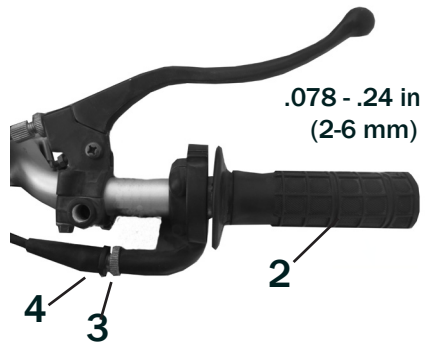

.078 - .24 in
(2-6 mm)

WARNING

Inadequate throttle play can be hazardous

The engine speed could rise when the handlebars are turned if there is not enough throttle play. This could result in loss of control.

Always check throttle play before each ride. Turn handlebars from side to side making sure throttle does not increase when doing so.

MAINTENANCE

Brakes

Front brake: Right hand lever adjustment

The front right brake lever (1) should have 4.0mm - 6.0mm (0.16 - 0.24 in.) of free play.

To adjust brake lever free play:

1. Loosen Jam nut (2) on the brake cable.
2. Turn adjuster nut (3) until the correct amount of free-play is achieved.
3. Re tighten jam nut (2)
4. The freeplay can also be adjusted by loosening jam nut (4) on the front brake drum assembly.
5. Turn adjuster nut (5) on the front brake drum assembly until the correct free play is achieved.

4.0 - 6.0mm
(0.15 - 0.24 in)

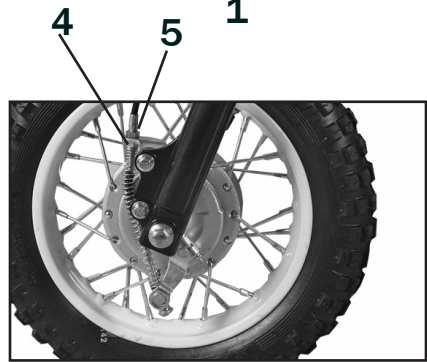
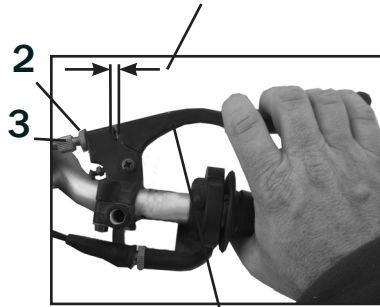

Rear brake: Foot lever adjustment

The Rear Foot Brake lever (6) should have 19-25mm (0.75 - 1in) of free play.

To adjust foot lever free play

1. Turn the adjuster nut (7) until the correct amount of free-play is achieved.

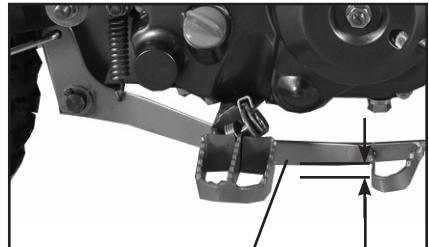

6 19 - 25 mm
(.75 - 1 in.)

WARNING

Failing to inspect the brakes before each use could be hazardous

Inspect brakes before each use according to the Pre Ride inspection chart, make sure to follow the maintenance schedule and procedures.

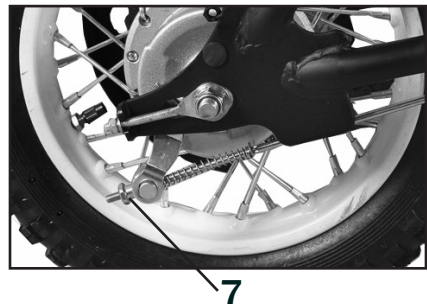

MAINTENANCE

Fuel Hose Inspection

Inspect the fuel hose (1) for any cracks or leaks and make sure all clamps are in place. Replace the fuel hose if any defects are found.

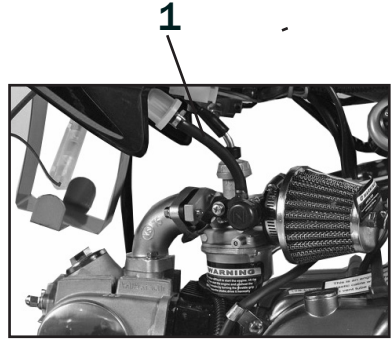

Valve Clearance:

Adjusting the valves should be done by an authorized service center or comparable servicing dealer. Proper valve gap will help Dirt Bike to run at peak performance. Follow the valve gap adjustment intervals listed in the maintenance chart.

Proper Valve Clearance

Intake: 0.002 in (0.05mm)
Exhaust: 0.003 in (0.07mm)

MAINTENANCE

Chain

Chain and sprocket inspection

Inspect the drive chain for wear, rust, bound links, proper lubrication and proper tension.

If the drive chain has a problem correct or replace. Contact a service center for chain replacement.

A worn drive chain could also mean the sprockets may be worn.

Look for the following on the sprockets (1): Worn teeth broken or damaged teeth, loose sprocket mounting nuts.

If the sprocket shows signs of wear, contact a service center for replacement.

Chain tension

Check the tension of the chain , The chain (1) tension should be 5 - 15mm (0.2 - 0.6in)

Chain tension (slack) adjustment

1. Loosen the Rear axle bolt (2)
2. Adjust chain tension by turning the tensioner nuts (one on each side of dirt bike) (3). Clockwise will tighten the chain. Counter clockwise will loosen the chain.
3. Once the chain is at the correct tension re-tighten Axle bolt (2).
4. Re-check chain tension.

NOTE: Adjusting the chain tension will affect the rear braking. Always check rear brake performance and adjust as necessary before riding.

Chain lubrication

Lubricating the chain before each ride will help to ensure maximum life of the chain and sprockets.

Instructions for cleaning and chain lubrication:

1. Clean chain with water and allow to dry.
2. Lubricate chain with chain lube.

1

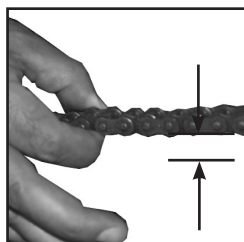

5 - 15mm
(0.2 - 0.6in)



2

3

MAINTENANCE

Tires

Inspect tires before each ride, this should include the following:

1. Inspect for cracks or leaks
2. Inspect tread depth. If tread depth is below 4mm (.16 in.) replace the tire.
3. Check tire pressure. Incorrect tire pressure can affect the handling, rider comfort, steering, tire life and traction. Always check the tire pressure before each ride.

Tire pressure

Front tires: 32psi (225 kpa)

Rear tires: 36psi (250 kpa)

Tire size:

Front tires: 2.5 - 10

Rear Tires: 2.5 - 10

Replacing tires

Always replace tires with type and size listed in this manual.

Always use the correct tools when replacing tires. The bead and sometimes the rim can be damaged by using the wrong type of tools. It is usually best to have tires replaced by an authorized service center. Service centers have the correct equipment and expertise to change tires without causing damage.

Minimum tread
4mm (.16 in.)

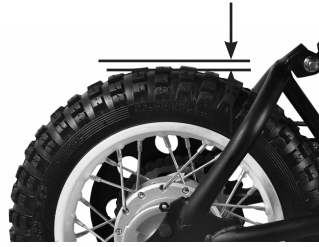

⚠ WARNING

Operating this Dirt Bike with worn tires could be hazardous

Operating this Dirt Bike with worn tires will reduce traction which could result in an accident.

Never operate this Dirt Bike with tires that have a tread depth of less than 4mm (0.16 in.)

⚠ WARNING

Operating this Dirt Bike with improper tire sizes or pressure could be hazardous

Operating this Dirt Bike with improper tire sizes or pressure could result in loss of control of the Dirt Bike which could result in an accident.

Never operate this Dirt Bike with improper tire sizes or pressure.

STORAGE

Storage

If the Dirt Bike is left unused for an extended period of time proper storage maintenance is required.

1. Wash Dirt Bike thoroughly, then wax plastics and painted parts with a non abrasive auto wax. Coat vinyl seat and rubber parts with a vinyl/rubber protectant. Note: Keep water away from air intake and muffler outlet while washing to avoid water from entering the engine and/or components.

2. Drain carburetor by turning fuel valve (1) to the off position and opening the drain screw (2). Allow all fuel to drain from the carburetor. Once fuel is drained, re-tighten drain screw (2).

Note: Make sure to drain fuel in a proper storage container.

3. Fill fuel tank to full with gasoline mixed with fuel stabilizer as recommended by the fuel stabilizer manufacture. Note: Fuel stabilizer can be purchased at most motorcycle shops and auto parts stores.

4. Remove spark plug and pour 1 tablespoon of motor oil in the spark plug hole. Re-install spark plug.

5. Kick the starter lever approximately 5 times with the ON/OFF switch in the OFF position. This is to coat the inside cylinder head with oil.

6. Cover the muffler outlet and air intake with oily rags so the Dirt Bike will be protected from humidity in storage.

7. Fill tires with correct air pressure.

8. If possible, store Dirt Bike in a shed or garage with a cover to protect from dust, dirt and humidity. If the Dirt Bike must be stored outdoors, cover Dirt Bike completely with a good waterproof cover.

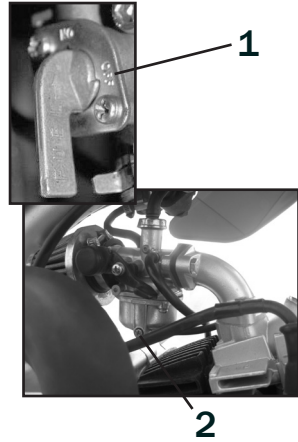

Returning to service

1. Wash Dirt Bike thoroughly. Note: Keep water away from air intake and muffler outlet while washing to avoid water from entering the engine and/or components.

2. Remove oily rags from air intake and muffler outlet.

3. Drain engine oil and replace with fresh clean oil as listed in this manual.

4. Review this owner's manual and follow the pre-ride inspection procedures.

5. Start engine by following the starting procedures in this manual.

WASHING THE DIRT BIKE

Washing the Dirt Bike

1. Wash mud and dirt off Dirt Bike with low pressure water from a hose.

2. Wash Dirt Bike using a mild detergent or car soap using a sponge, soft rag or brush. Do not use any cleaning materials that could scratch the Dirt Bike.

Note: Be careful not to allow water to enter the muffler outlet, air filter intake, brake cables or switches.

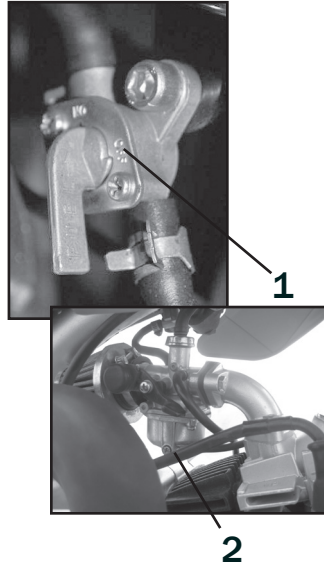

Transporting

1. Make sure fuel valve (1) is turned to the OFF position.

2. Drain carburetor by turning fuel valve (1) to the off position and opening the drain screw (2). Allow all fuel to drain from the carburetor. Once fuel is drained, re-tighten drain screw (2).

Note: Make sure to drain fuel in a proper storage container.

3. Transport the Dirt Bike with the Dirt Bike in the upright position (3) tied down securely.



TROUBLESHOOTING

Trouble	Possible cause	Solution
<p>Engine will not start</p>	<ul style="list-style-type: none"> • ON/OFF switch in the “OFF” position • Ignition key is in the “OFF” position • Low fuel • Stale or contaminated fuel. • Fuel valve is in the “OFF” position • Loose spark plug • Spark plug fouled or defective. • Spark plug gap is incorrect • Spark plug cap is not attached • Choke is not in the “ON “ (UP) position for starting a cold engine. • Problem with the electrical system 	<ul style="list-style-type: none"> • Place ON/OFF switch in the “ON” position • Place ignition key in the “ON” position • Fill with fresh fuel • Have a service center flush and fill with fresh fuel. • Place fuel valve in the “ON” position. • Tighten spark plug • Clean or replace plug • Gap the plug • Attach spark plug cap • Place choke in the “ON” (up) position • Take to a service center for repair
<p>Engine stalls or runs erratically</p>	<ul style="list-style-type: none"> • Low fuel • Stale or contaminated fuel • Choke is left in the “ON” (up) position • Spark plug is fouled or defective • Spark plug gap is incorrect • Spark plug cap is loose • Carburetor is clogged or has water in it • Idle is not adjusted properly • Problem with the electrical system 	<ul style="list-style-type: none"> • Fill with fresh fuel • Have a service center flush and fill with fresh fuel. • Place the Choke in the “OFF” (down) position. • Clean or replace plug • Gap the plug • Secure the spark plug cap • Take to a service center • Take to a service center • Take to a service center

SPECIFICATIONS

Engine

Displacement	72cc
Starting	Kick start
Spark Plug Type	NGK C7HSA
Cooling	Air cooled
Engine Oil Capacity	.85qt.(0.8L)
Ignition Type	CDI
Number of Cylinder	Single
Combustion Cycle	4-stroke
Compression ratio	8.8:1
Bore and Stroke	47x41.4mm
Max Power	3.7 KW/8500RPM
Torque	4.5 NM/8500RPM
Top Speed	37 mph (60km/h)
Idle RPM	1500 r/min ± 150 r/min

Transmission

Drive System Type	Chain Drive
Transmission	4 speed
Gear Ratios	1st gear 3.273
	2nd gear 1.938
	3rd gear 1.350
	4th gear 1.043

Suspension

Front	Front hydraulic
Rear Type	Mono shock

Braking

Front Brakes (Type)	Drum brake
Rear Brakes (Type)	Drum brake

Tires

Front Tire Size	2.50 X 10
Rear Tire Size	2.50 X 10

Dimensions and Weights

Length	1460mm (57.5inches)
Height	830 mm (32.7inches)
Width	520mm (20.5inches)
Wheelbase	930 mm (36.6 inches)
Vehicle Wt.	68 kg (150 lbs.)
Weight Cap.	75 kg (165lbs.)
Ground Clearance	147 mm (5.79 inches)

Fuel

Gas Tank Capacity	3.0L (.80 gal.)
Fuel type	Unleaded 87 octane or higher

Electrical Diagram

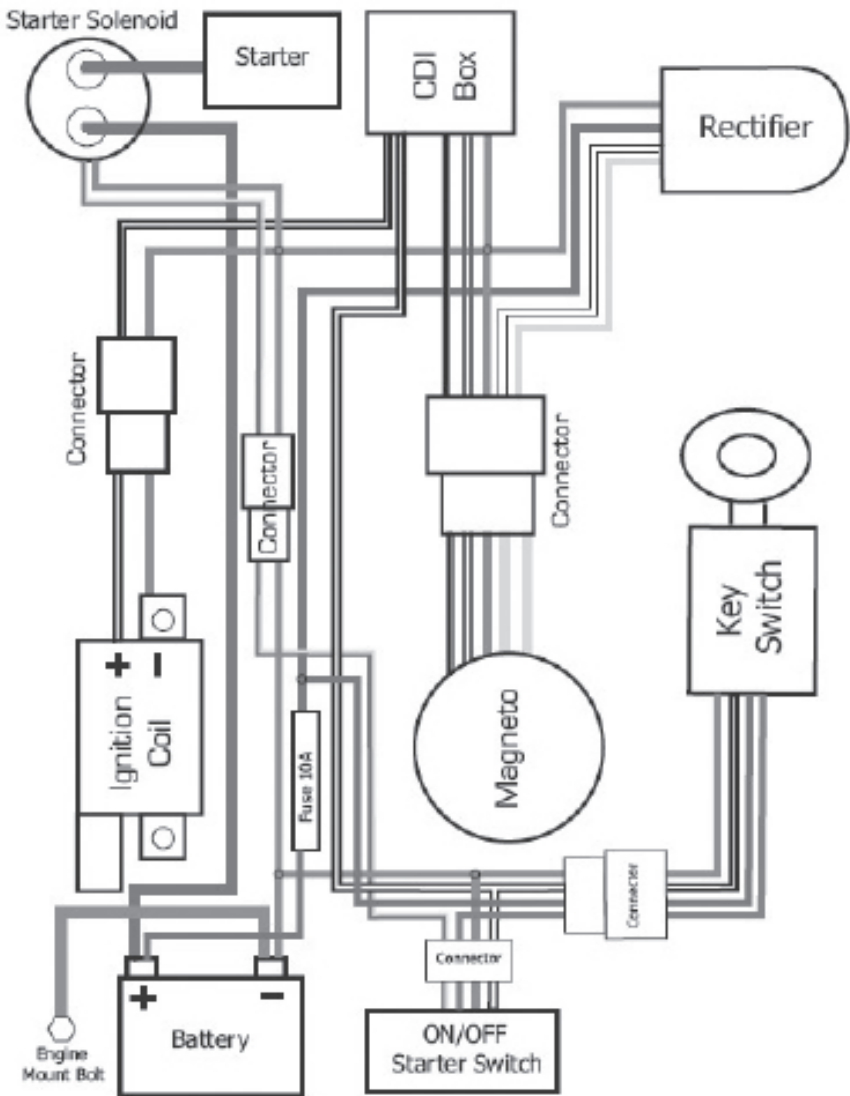

VIN# NUMBER LOCATION

The Vehicle identification number and the engine number are needed when calling for parts, service center help or when registering your Dirt Bike. Locate the numbers and list the numbers below for your reference.

VIN #



The 17 digit Vehicle Identification Number (VIN) is located on a plate on the left side of the Dirt bike frame.

Vehicle Identification Number

--	--	--	--	--	--	--	--	--	--	--	--	--	--	--	--	--

ENGINE #



The engine number is located on the left, bottom rear portion of the Dirt Bike Engine.

Engine Number

--	--	--	--	--	--	--

--	--	--	--	--	--	--	--

APOLLO MOTOR CORPORATION - Emissions Control System Warranty Statement

YOUR WARRANTY RIGHTS AND OBLIGATIONS

The emission control system warranty period for this vehicle begins on the date the vehicle is delivered to the first purchaser other than an authorized dealer, or the date it is first used as a demonstrator, lease, or company vehicle, whichever comes first and continues for 30 months after that date, or 5,000km, whichever comes first, provided there has been no abuse, neglect or improper maintenance of your vehicle. This warranty also applies to subsequent purchasers within the warranty period. Where a condition exists, the Distributor will repair your vehicle at no cost to you, including diagnosis, parts and labor. If an emission-related part on our vehicle is defective, the part will be repaired or replaced by the Distributor. This is your emission control defects warranty.

OWNER'S WARRANTY RESPONSIBILITIES

As the vehicle owner, you are responsible for the performance of the required maintenance. You should maintain a record of all maintenance performed on your vehicle and retain all receipts covering maintenance on your vehicle. You may not be denied a warranty claim solely because of your failure to ensure the performance of all scheduled maintenance or lack of maintenance records or receipts. You are responsible for presenting your vehicle to an authorized dealer as soon as a problem exists. The warranty repairs should be completed in a reasonable amount of time, not to exceed 30 days.

As the vehicle owner, you should be aware that you may be denied your warranty coverage if your vehicle or a part has failed due to abuse, neglect, improper maintenance, or unapproved modifications.

WARRANTY COVERAGE

The Distributor warrants that each new 2011 and later vehicle:

- is designed, built and equipped so as to conform at the time of initial retail purchase with all applicable regulations of the United States Environmental Protection Agency, and the California Air Resources Board; and
- is free from defects in material and workmanship which cause such vehicle to fail to conform with the applicable regulations of the United States, Environmental Protection Agency or the California Air Resources Board for the periods specified above.

Your emission control system warranty covers components whose failure would increase an engine's emission, including electronic controls, fuel injection system, carburetor, the ignition system, catalytic converter, or any other system utilized in this vehicle to control emissions if it is originally equipped. Also included may be hoses, connectors and other emission-related assemblies. Replacing or repairing other components (including parts,

labor and other costs) not covered by this emission control system warranty or the standard warranty is the responsibility of the owner.

Coverage of repairs under this warranty applies only when repairs are completed at an authorized dealer or repair facility. The Distributor will not cover repairs performed outside of an authorized dealer or repair facility, except in an emergency situation. The use of replacement parts not equivalent to the original parts may impair the effectiveness of your vehicle's emission control system. If such a replacement part is used and an authorized dealer or repair facility determines it is defective or causes a failure of a warranted part, your claim for repair to bring your vehicle into compliance with applicable standards may be denied.

If an emergency situation exists when a warranted part or a dealer is not reasonably available to the owner, repairs may be performed at any available service establishment, or by the owner, using any replacement part. The Distributor shall reimburse the owner of the expenses, including diagnostic charges, not to exceed the Distributors suggested retail price for all warranted parts replaced and labor charges based on the Distributors recommended time allowance for the warranty repair and the geographically appropriate hourly rate. The owner may reasonably be required to keep receipts and failed parts in order to receive compensation.

The Emission Control System Warranty is in addition to the standard Limited Warranty

EXCLUSIONS AND LIMITATIONS

This warranty does not cover the following:

- Failures or malfunctions of the emission control systems caused by abuse, alteration, accident, misuse, the use of lead gasoline.
- Replacement of expendable maintenance items unless they are original equipment defective in material or workmanship under normal use, and the first required replacement interval for the item has not been reached. Expendable maintenance items include but are not limited to spark plugs, filters, coolant, lubricants, gaskets, hoses, and belts.
- Replacement of parts and other services and adjustments for required maintenance.
- Any vehicle equipped with an odometer or hour meter where the reading is altered so that actual mileage cannot be readily determined.
- Repairs or replacements as a result of:
 - Accident
 - Misuse
 - Use of replacement parts or accessories not conforming to the original specifications which adversely affect performance.
- Physical damage, corrosion, or defects caused by fire, explosions or similar caused beyond the control of the Distributor.
- Failures not caused by a defect in material or workmanship.

Use of the vehicle in any type of racing or related events immediately and completely voids this and all other warranties.

LIMITED LIABILITY

The liability of the Distributor under the Emission Control System Warranty is limited solely to the remedying of defects in material and workmanship by an authorized dealer at its place of business during customary business hours. This warranty does not cover inconvenience or loss of use of the vehicle or transportation of the vehicle to or from the authorized dealer. The Distributor is not liable to any person for incidental, consequential or special damages of any description, whether arising out of express or implied warranty or any other contract, negligence or other tort or otherwise.

No express emission control system warranty is given by the Distributor except as specifically set forth herein. Any emission control system warranty implied by law, including any warranty of merchantability or fitness for a particular purpose is limited to the express emission control system warranty terms stated in this warranty. The foregoing statements of warranty are exclusive and in lieu of all other remedies. All express warranties not stated in this warranty are disclaimed. Some states do not allow limitations on how long an implied warranty lasts, so the above limitations may not apply if it is inconsistent with the controlling state law.

No dealer is authorized to modify this Emission Control System Warranty. If you have any questions regarding your warranty rights and responsibilities, you should contact Apollo Motor Corporation at 818-588-8435 (or you can write to 1528 N. Dominion Ave., Pasadena, CA. 91104) or the California Air Resource Board, 9528 Telstar Ave., El Monte, CA. 91731 (for California registered vehicles only).



POWERSPORTS

**364 S. Smith Rd
Tempe, AZ. 85281**

**PHONE: Toll Free (888) 405-8725
colemanpowered.com**