



POWERSPORTS

## OWNER'S MANUAL



**CT200U-A**

Recommended  
Age 13+

Provincial / Municipal governments have different regulations pertaining to owning and operating an off-road vehicle, learn the regulations in your area.

**(888)-405-8725 Coleman Powersports**  
**1775 E. University Dr. Tempe, AZ. 85281**

[www.colemanpowered.com](http://www.colemanpowered.com)

REV#012318

# To the Owner

Congratulations on your purchase of a Coleman Powersports Off-Road Mini Bike. This Owner's/Operator's manual will provide you information regarding safe operation, operational instructions, maintenance and care. Fully understanding this manual and following all of the instructions herein will provide the knowledge needed to have safe and enjoyable operation.

For questions regarding operation and maintenance of this Off-Road mini bike, please call Coleman Powersports toll free 888-405-8725.

## **Safety - Notice to parents**

Children differ in skills, physical abilities, and judgement. Some children may not be able to operate a Mini Bike safely. Parents should supervise their child's use of the Mini Bike at all times. Parents should permit continued use only if they determine that the child has the ability to operate the Mini Bike safely.

THIS MINI BIKE IS NOT A TOY AND COULD BE HAZARDOUS TO OPERATE.

## **Reading the Owner's/ Operator's Manual**

It is important this manual is read from cover to cover carefully by the owner and all operators.

This Owner's/ Operator's manual should be a permanent part of the mini bike and should remain with the vehicle at all times. The manual should also remain with the vehicle if sold.

To emphasize special important information in the manual, please note the following :



This is the alert symbol. The symbol means ATTENTION!, BECOME ALERT!,

To emphasize important safety information, the word WARNING, with the alert symbol, has special meaning.:



Indicates a potential hazard that could result in SEVERE INJURY or DEATH to the operator, bystander

To emphasize important information, the word CAUTION has special meaning.:

**CAUTION:**

Indicates special precautions that must be taken to avoid damage to the unit.

To emphasize important information, the word NOTE has special meaning.:

**NOTE:**

Indicates key information to make procedures easier or clearer to understand.

**! WARNING or CAUTION**

The first part will identify a POTENTIAL HAZARD.

The second part will describe WHAT COULD HAPPEN if the warning or caution is ignored.

The third part will describe HOW TO AVOID THE HAZARD.

Coleman Powersports is concerned about the environment and believes in conserving and protecting all natural resources. For this reason, owners should recycle, trade in, or dispose as appropriate, oil and tires.

This manual is based on the latest product information available at the time of publication. Coleman Powersports has a policy of continually improving its products. Due to improvements, or other changes, there may be some discrepancies. We reserve the right to make product changes at any time, without notice and without incurring any obligation to make the same or similar changes to vehicles previously built or sold.

 **WARNING**

The engine exhaust from this mini bike contains chemicals known to the state of California to cause cancer, birth defects or other reproductive harm.

# TABLE OF CONTENTS

COLEMAN POWERSPORTS WARRANTY.....	2	CHAIN AND SPROCKET.....	23
IMPORTANT SAFETY LABELS.....	4	INSPECTION.....	23
LOCATION.....	4	TENSION AND ADJUSTMENT....	23
LABELS.....	5	CLEANING AND LUBRICATION..	23
SAFETY .....	6	CLEANING AND INSPECTING	
DESCRIPTION AND PART LOCATIONS..	7	CENTRIFUGAL CLUTCH.....	24
DESCRIPTION AND PART FUNCTIONS..	8	TIRES.....	25
RIGHT HAND THROTTLE GRIP.....	8	REPLACING.....	25
ENGINE STOP SWITCH.....	8	STORAGE.....	26
LEFT HAND BRAKE LEVER.....	8	RETURNING TO SERVICE.....	26
CHOKE OPERATION.....	9	WASHING THE MINI BIKE.....	27
FUEL VALVE OPERATION.....	9	TRANSPORTING.....	27
FUEL CAP.....	9	TROUBLE SHOOTING.....	28
STARTER RECOIL CORD.....	9	SPECIFICATIONS.....	29
OIL FILL PLUG.....	9	FRAME AND ENGINE NUMBER	
FUEL AND OIL.....	10	LOCATION.....	30
FUEL.....	10	EMISSION CONTROL SYSTEM	
ENGINE OIL.....	10	WARRANTY.....	31
PRE RIDE INSPECTION.....	11		
RIDING MINI BIKE.....	12		
HELMET, EYE PROTECTION AND			
PROTECTIVE CLOTHING.....	12		
STARTING THE ENGINE.....	13		
STARTING OFF.....	14		
LOAD GUIDELINES.....	15		
MAINTENANCE.....	16		
MAINTENANCE CHART.....	17		
AIR FILTER.....	18		
SPARK PLUG.....	19		
ENGINE OIL .....	20		
CHECKING.....	20		
CHANGING.....	20		
THROTTLE CABLE ADJUSTMENT.....	21		
FUEL HOSE INSPECTION.....	21		
BRAKES.....	22		
BRAKE LEVER ADJUSTMENT..	22		
BRAKE ADJUSTMENT.....	22		
VALVE CLEARANCE.....	22		

## COLEMAN POWERSPORTS LIMITED WARRANTY

This Warranty is NOT the Emissions Control Warranty

Please note this is a general Limited Warranty for this product. It IS NOT an Emissions Control Warranty. Please see the Emissions Control Warranty in this manual for warranties covering Emission components. The Emissions Control Warranty can be found on page 31.

### The Warranty

Coleman Powersports offers the following warranty to the initial purchaser of this new Coleman Powersports product. The initial purchaser is defined as the first person to purchase a new Coleman Powersports product from an Authorized Retailer.

The limited warranty period for this product is 90 days from the date of purchase shown on the original sales receipt.

### What is a Defect?

The Product is warranted to be free from manufacturing defects in material and workmanship for a period of 90 days from the date of purchase shown on the sales receipt. During this period of time Coleman Powersports will, at its option, either repair, refund purchase amount, or replace any original Coleman Powersports unit/part which is covered by this warranty and is proven to be defective in workmanship or material.

To qualify for this warranty the part:

1. Must have been purchase from Coleman Powersports or from an authorized Coleman Powersports Retailer.
2. Must have been used in a manner consistent with the intended use for the vehicle. This warranty does not apply to any vehicle which is used in competition or used in a manner not consistent with the intended use for the vehicle which would also include rental or commercial use.

### Who Can Perform Repairs Under this Warranty?

Repairs under this warranty should be performed by an authorized Coleman Powersports retailer or comparable servicing dealer.

### How to get service under this warranty

To get warranty service call Coleman Powersports at 888-405-8725 for the location of your local servicing retailer / dealer. Please do not return the product to the retailer where the product was purchased unless instructed to do so by Coleman Powersports. The retailer of this product does not make any warranty of its own and has no authority to implement this warranty on behalf of Coleman Powersports without the approval of Coleman Powersports. A COPY OF YOUR SALES RECEIPT IS REQUIRED FOR WARRANTY SERVICE.

## What this Warranty Does Not Cover

This warranty does not cover the following

1. Damage to lack or improper maintenance as describe in this manual.
2. Damage which is caused by normal use and not cause by a defect in materials or workmanship.
3. Use of the product which is not consistent with the intended use as described in the operating instructions.
4. Any expendable maintenance items which needs replacement or service as normal maintenance requires unless these normal maintenance items become defective prior to their normal life due to a material defect or a defect in workmanship.
5. Any product which has been altered or modified in a manner not consistent with the original design of the product or in a manner not approved by Coleman Powersports.
6. Tires
7. Damage or failures due to abuse, neglect, or misuse of the product.

### Limitations of this Warranty

This warranty does not cover and Coleman Powersports disclaims any responsibility for:

1. Loss of time or loss of use of the product.
2. Transportation costs to and from the authorized center.
3. Other loss or damage to other equipment or personal items.

### Length of Implied Warranties

Any implied warranties are limited to the duration set forth in this warranty. Coleman Powersports does not make any claim as to the merchantability or fitness for a particular purpose which would extend longer than the duration of this written warranty.

Check your State Laws as some State Laws do not allow limitations as to the duration of an implied warranty. Some States may also not allow limitation or exclusions based on incidental or consequential damages.

# IMPORTANT LABELS

LOCATION

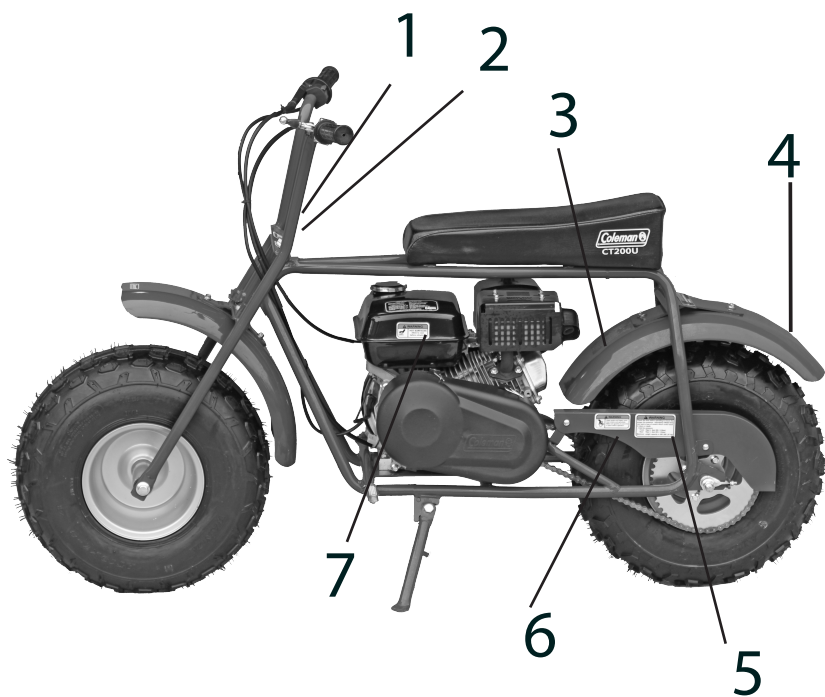



# Warning Labels

1

**⚠ WARNING**

THIS VEHICLE IS AN OFF-ROAD VEHICLE AND IS NOT INTENDED FOR USE ON PUBLIC ROADS/HIGHWAYS

2

**⚠ WARNING**

Check the following before operating.

1. Engine oil level.
2. Lubricate and adjust drive chain if necessary.
3. Clean and Lubricate clutch.
4. Insure all Guards are in place.

4

**DO NOT RETURN TO STORE!**  
FOR SERVICE AND REPAIR, PLEASE  
CALL COLEMAN POWERSPORTS  
TOLL FREE 888-405-8725

3

**⚠ WARNING**

This Mini Bike can cause serious injury or death if the warnings and instructions in the owner's manual and on warning labels are not followed.

**Never Operate this Mini Bike:**

- at speeds too fast for your skills or the conditions.
- on public roads, a collision can occur with another vehicle.
- carrying a passenger, a passenger can affect balance and control.
- while under the influence of alcohol or drugs
- with long hair or loose clothing unconstrained. Long hair and loose clothing can get caught in moving parts of the mini bike and cause serious injury or death.
- operate this mini bike in an unsafe manner by attempting stunts, jumps or wheelies. This could lead to severe injury or death.

**Always:**

- wear a DOT certified helmet, eye protection, gloves, over the ankle boots, long sleeve shirt and long pants.
- avoid paved surfaces, paved surfaces can adversely affect handling and control.
- keep hands and feet away from all moving parts.
- Check the throttle to ensure it works properly and "snaps back" prior to starting the mini bike.
- be seated before attempting to start the mini bike.
- continually supervise children

Recommended age 13 +

5

**⚠ WARNING**

Check the tires before operating to insure the proper tire pressure. Improperly inflated tires can lead to loss of control which could result in injury or death.

**Cold tire pressure:**

Front: 10psi ± .5psi (69 ± 3.5kpa)  
Rear: 10psi ± .5psi (69 ± 3.5kpa)

**Maximum weight capacity is 200 LBS. (91 kg)**

6

**⚠ WARNING**

Keep hands and fingers away from chains and sprockets. Make sure guards are securely in place before operation.

7

**⚠ WARNING**

 **HOT SURFACES**  
Allow to cool  
before refueling

# SAFETY

This Mini Bike is recommended for riders 13 and older.

Always wear a certified DOT or motorcycle type helmet that fits properly, over the ankle boots, eye protection, gloves, long sleeve shirt and long pants while operating this mini bike.

Never allow a passenger on this mini bike. This mini bike is designed for one operator and no passengers.

Never operate this mini bike on paved surfaces and/or public roads. Pavement may cause the mini bike to become unstable. The tires on the mini bike are for off-road use only.

Always go slowly and pay attention to unfamiliar terrain. Be alert to changing terrain conditions when operating the Mini bike.

Never operate with long hair or loose clothing unconstrained. Long hair and loose clothing can get caught in moving parts of the mini bike .

Never take drugs or alcohol before or during operation of this mini bike.

Never traverse, climb or go down a hill that is too steep. Avoid hills with loose or slippery terrain.

Never attempt wheelies, jumps or any other type of stunts on this mini bike.

Always follow the pre-ride inspection procedures and maintenance procedures located in this manual before use.

Always go slow on terrain that is not familiar, be alert, an obstacle could come up unexpectedly.

Always keep both hands on the handlebars and both feet on the foot pegs, doing so will help the operator be ready for unexpected situations.

Do not operate in fast flowing water. Water can affect the braking performance of the mini bike. Check braking performance after exposure to water, it may be necessary to apply the brakes allowing friction to dry out the pads.

Always Check the throttle to ensure it works properly and “snaps back” to idle prior to starting the mini bike.

# DESCRIPTIONS AND PART LOCATIONS

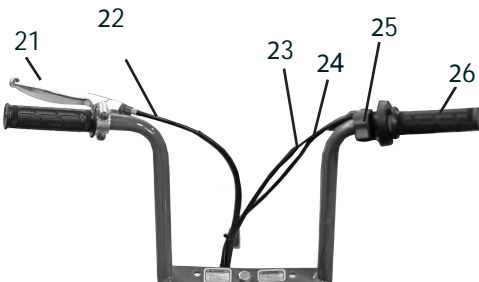
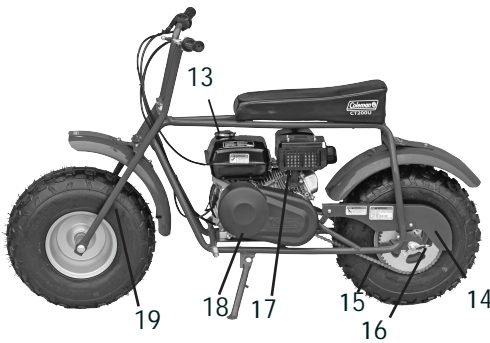
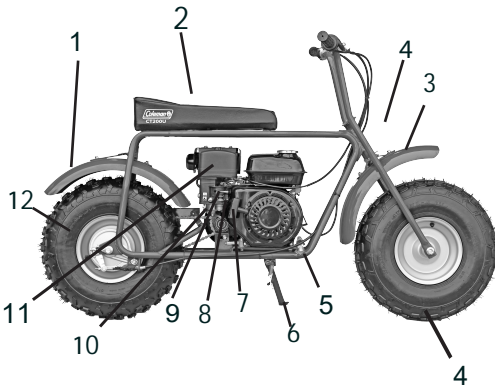

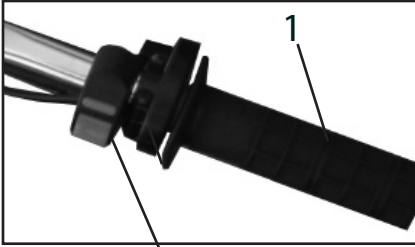

1. Rear Fender
2. Seat
3. Front Fender
4. Front Wheel
5. Foot Pegs
6. Kick Stand
7. Starter Recoil
8. Fuel Valve
9. Choke Lever
10. Carburetor
11. Air filter assembly
12. Rear Wheel
13. Fuel Tank and Cap
14. Chain Guard
15. Chain
16. Chain adjustment bolts
17. Muffler
18. Clutch Cover
19. Front Fork assembly
20. Left Hand Grip
21. Rear Brake Lever
22. Rear Brake Cable
23. Throttle Cable
24. ON/OFF Switch Wire
25. ON/OFF Switch
26. Throttle Grip

# DESCRIPTION AND PART FUNCTIONS

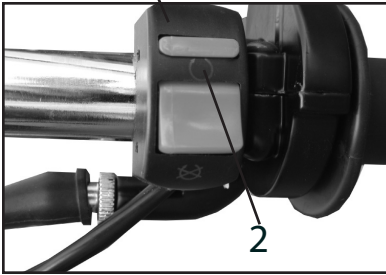

Right Throttle Grip(1): The engine speed is regulated by the position of the right throttle grip. Throttle is increased by turning the throttle grip toward the operator. Engine speed is decreased by turning the throttle grip away from the operator.



Engine Stop Switch (2): Mini Bike engine can start when the Engine stop switch is placed in the  (on) position. Engine will shut off and the engine will not start when the switch is placed in the  (off) position.

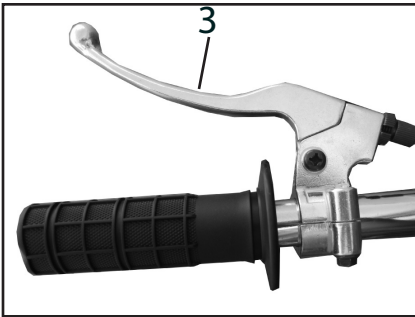

Left hand brake lever (3): The rear brake is applied when the left hand brake lever is pulled toward the hand grip.

# DESCRIPTION AND PART FUNCTIONS

## Choke operation



Choke Lever (1): If the engine is cold, the choke can help start the engine by placing the choke lever to the "ON" (left) position. Once engine has warmed up, place choke lever to the "OFF" (right) position.

## Fuel Valve operation

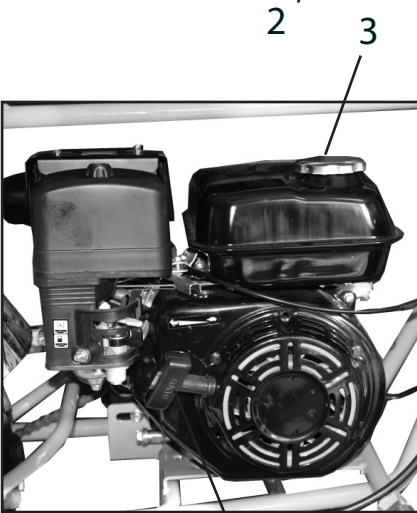

Fuel Valve (2): To start the engine and run the mini bike, the fuel valve needs to be placed in the "ON" (right) position. This allows fuel to flow to the carburetor.

When finished riding, and while transporting, place fuel valve in the "OFF" (left) position.

## Fuel Cap

### Fuel Tank Cap

To open the fuel tank cap (3), Turn the cap counter clockwise to remove. To re-install the cap, turn the cap clockwise until snug.

## Starter Recoil Cord

### Starter Recoil Cord (4)

To start the engine, place the on/off switch locate on the handlebars to the "ON" position and pull the Starter Recoil Cord

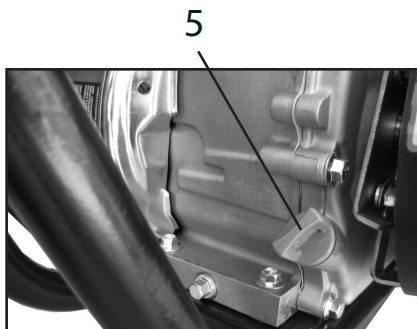

## Oil Fill plug

### Oil Fill Plug (5)

To check or add oil, open the oil fill plug/dipstick by turning counter clockwise. To tighten, turn clockwise.

# FUEL AND OIL

## FUEL

Never use leaded gasoline in this product. It could affect the engine's emissions and damage the engine. Mini Bike requires clean unleaded regular gasoline with a minimum octane rating of 90 or higher.

### Gasoline/ Ethanol blends

A blend of unleaded gasoline with Ethanol, also known as GASOHOL, at or below 10% (E10) can be used in your Mini Bike. Ethanol greater than 10% can damage your engine and will void your warranty.

### Gasoline/Methanol Blends

A blend of gasoline with Methanol of 5% or less can be used in your Mini Bike. Do not use gasoline, under any circumstances, containing more than 5% Methanol, doing so will damage your engine and will void the warranty.

## Fuel Filling

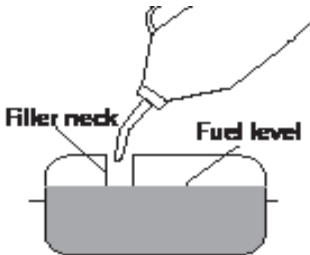

## ⚠ WARNING

Over filling the fuel tank can cause the fuel to expand which can cause overflow due to the heat from the engine or sun. Spilled fuel can catch fire.

Never fill the fuel tank above the filler neck.

## ⚠ WARNING

Fuel and fuel vapor are highly flammable and toxic. You can be burned or poisoned while refueling.

Before refueling make sure to follow the procedures listed:

- 1 Shut off engine, Make sure there are no flames, sparks or heat sources close by.
- 2 Refuel only outdoors in a well ventilated area.
- 3 Do not smoke while refueling.
- 4 Wipe up any spills immediately.

## ENGINE OIL

The recommended oil for this Mini Bike is SAE10W-30 motor oil, if this oil is not available, any of the oils on the chart below will work. Note the temperature requirements for each of the oils.

Quantity of oil - .63qt. (.6L).

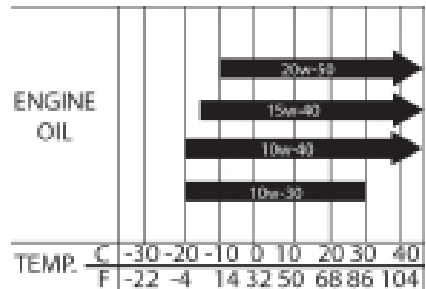

# PRE-RIDE INSPECTION

Inspecting and checking the condition of the Mini Bike before each ride is important. Following the pre-ride check list will help insure the you do not have mechanical problems which could result in injury or becoming stranded. Make sure the Mini Bike is in good operating condition before each ride.

## ⚠ WARNING

Failing to inspect and maintain your Mini Bike could be hazardous.

Not following the pre-ride inspection procedures could result in losing control of the Mini Bike resulting in an accident or damage to the Mini Bike

Always perform a Pre-ride inspection before each ride.

## ⚠ WARNING

Performing maintenance and checks while the engine is running could be hazardous.

You could be severely injured by moving parts or hot surfaces.

Never perform maintenance or check procedures while the engine is running with the exception of checking the engine stop switch or throttle.

WHAT TO CHECK	CHECK FOR
Steering	<ul style="list-style-type: none"> <li>• Smoothness</li> <li>• No restriction of movement</li> </ul>
Brakes	<ul style="list-style-type: none"> <li>• Brake shoe wear.</li> <li>• Proper brake lever play</li> </ul>
Tires	<ul style="list-style-type: none"> <li>• Proper tire pressure</li> <li>• Proper tread depth</li> <li>• Rubber has no cracks</li> </ul>
Fuel Tank	<ul style="list-style-type: none"> <li>• Enough fuel for the ride</li> <li>• Fuel cap secure</li> <li>• Hoses have no signs of cracks or leaks</li> </ul>
Throttle grip	<ul style="list-style-type: none"> <li>• Throttle grip snaps back to idle when released</li> <li>• Operates freely</li> <li>• Has correct free play</li> </ul>
Engine Stop Switch	<ul style="list-style-type: none"> <li>• Switch shuts off engine when activated.</li> </ul>
Engine Oil	<ul style="list-style-type: none"> <li>• Correct oil level</li> </ul>
Drive Chain	<ul style="list-style-type: none"> <li>• Proper tension</li> <li>• Lubricated</li> <li>• No excessive wear or damage</li> </ul>
General Condition	<ul style="list-style-type: none"> <li>• All nuts and bolts tight</li> <li>• No rattles from engine or frame while running</li> </ul>

# RIDING THE MINI BIKE

## HELMET, EYE PROTECTION, PROTECTIVE CLOTHING

Always wear a DOT or SNELL certified motorcycle helmet (1). A helmet helps protect against serious head injuries in the event of an accident. A helmet is the most important safety gear item you can wear. Consult with a motorcycle dealer for the correct size and type of motorcycle helmet that is right for you.

Always wear eye protection when riding a Mini Bike such as a face shield or goggles (2). While riding a Mini Bike you can be hit in the eyes by any of the following: dust, branches, rocks, debris from other riders, bugs, etc. Good eye protection as well as a helmet and protective riding gear should be mandatory when riding a Mini Bike.

Wear protective clothing: Long sleeve shirt (3), Gloves (4), Long pants (5), over the ankle boots (6). Riding a Mini Bike exposes the rider to many hazards, wearing protective clothing can help protect the rider from injury.

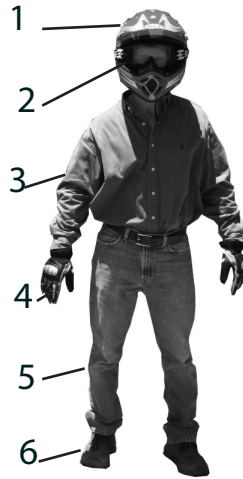

### **⚠ WARNING**

Riding the Mini Bike without a helmet, eye protection, and protective clothing can be hazardous

Riding a Mini Bike without a helmet increases the chance of severe head injury or death in the event of an accident.

Riding a Mini Bike without eye protection such as a face shield or goggles could result in severe injury in the event of an accident.

Riding a Mini Bike without protective clothing; over the ankle boots, long pants, gloves, long sleeve shirt could result in severe injury in the event of an accident.

Always wear a Helmet, eye protection, long pants, long sleeve shirt, over the ankle boots and gloves when riding the Mini Bike.



# RIDING THE MINI BIKE

## STARTING ENGINE

To start the engine

1. Place the fuel valve (1) in the "ON" (right) position.
2. If engine is cold, place the choke lever (2) in the "ON" (left) position.
3. Place the ON/OFF switch (3), located on the handlebars, in the (on) position.
4. Pull the starter recoil cord (4) to start the engine.
5. Once engine has warmed up for a few minutes, place the choke lever (2) back to the "OFF" (right) position.

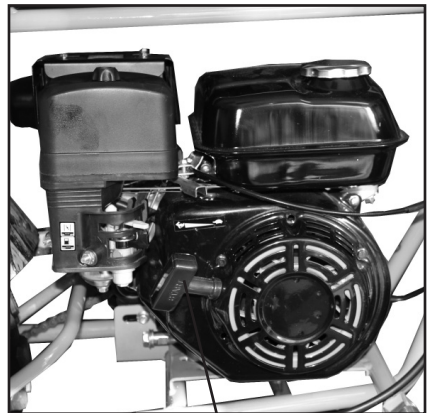
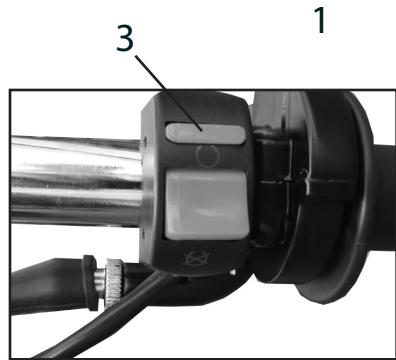
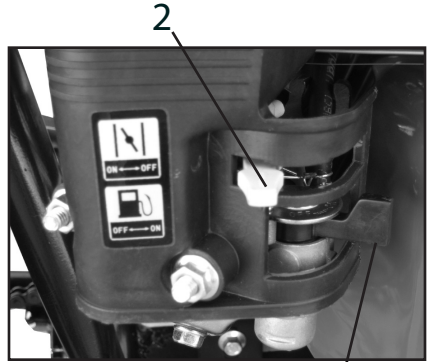

## **⚠ WARNING**

Starting or running the Mini Bike in an enclosed area such as a garage or shed where there is no ventilation is hazardous

Inhaling exhaust fumes from the Mini Bike can cause severe injury or death

Never start or run the Mini Bike in an inclosed environment where there is no ventilation. Always start and run outdoors.

# RIDING THE MINI BIKE

## STARTING OFF

1. Start and warm up the engine according to the instructions in this manual.
2. Place the side kick stand in the up position.
2. Apply the throttle gradually to start riding. Practice riding mini bike on a flat dirt surface that has plenty of room for turning.

### **WARNING**

Turning the throttle grip to full throttle when starting off could be hazardous.

The Mini Bike could lurch forward causing the front wheels to leave the ground causing loss of control.

Always open the throttle gradually when starting off from a stopped position.

### **WARNING**

Operating this Mini Bike at excessive speeds could be hazardous.

Riding at excessive speeds increases your chances of losing control of the Mini Bike, which could result in severe injury or death.

Always go at a speed that is proper for the terrain, visibility, operating conditions, operator skill, and operator experience. Always know the terrain before riding.

### **WARNING**

Removing hands from the handlebars and/or feet from the footrest while operating the Mini Bike could be hazardous.

Removing both or one hand from the handlebars and/or feet from the footrests could result in loss of control of the Mini Bike resulting in severe injury or death.

Always ride with both hands on the handle bars and both feet on the footrests while operating the Mini Bike.

### **WARNING**

Braking while turning could be hazardous.

Braking while turning could cause the Mini Bike to slide out of control which could result in severe injury or death.

Before making a turn, slow down and release the brake.

# RIDING THE MINI BIKE

## Load Guidelines

Load guidelines including accessories:

Never exceed the maximum load capability of the Mini Bike. This includes the weight of the rider and any cargo. This Mini Bike is rated at 200 lbs. (91kg).

Do not add any accessory or cargo to the handlebars that could impede vision or make the Mini Bike harder to steer.

Make sure accessories do not get in the way of any controls of the Mini Bike.

## After Market parts

After market parts and accessories may be available from other manufactures. Coleman Powersports cannot confirm the quality, safety or suitability of accessories available. When purchasing an accessory, use caution, the handling of the Mini Bike could become affected. Some accessories may make the Mini Bike unsafe to ride. If you have a question about a modification or accessory, contact your dealer or call Coleman Powersports.

## WARNING

Riding this Mini Bike with modifications or adding accessories could be hazardous.

Modifications to the Mini Bike, including adding accessories, could adversely affect the handling of the Mini Bike causing an accident which could result in severe injury or death.

Never Modify this Mini Bike in any way, including adding accessories, unless the modification is a genuine certified modification or accessory approved by the manufacture. Never modify the Mini Bike with improper installation. Make sure to follow all instructions recommended in the certified modification. Use only genuine parts. For questions, contact your dealer.

# MAINTENANCE

For maintenance, your mini bike may be maintained by an authorized Coleman Powersports service dealer or a repair shop of your choosing. Following the proper maintenance procedures and time table for maintenance listed in this manual is important for the safety of the rider and the life span of the Mini Bike. When riding in harsh conditions, such as water, mud and dust, the maintenance procedures should be performed more often.

## WARNING

Failing to perform the recommended maintenance on this Mini Bike could be hazardous.

Failing to perform proper maintenance on this Mini Bike could result in an accident

Always perform the recommended maintenance for the Mini Bike as listed in this manual.

## WARNING

Performing maintenance and inspection while the engine is running could be hazardous.

Performing maintenance and inspections while the engine is running could result in getting body parts or clothing caught in moving parts, or could result in touching hot items which could result in severe injury.

Shut off engine when performing maintenance and inspection checks, with the exception of checking the engine stop switch and throttle.

## CAUTION

Failing to perform recommended maintenance on this Mini Bike could damage the Mini Bike engine and components

Always perform the recommended maintenance on this Mini Bike as listed in this manual.

Maintenance will need to be performed more often if ridden in wet, muddy or dusty conditions.

## CAUTION

Failing to use compatible parts with the original replacement parts could damage Mini Bike

Using parts that are of low quality could result in Mini Bike breakdowns and reduce the useful life of the Mini Bike.

Never use parts that are not compatible with the original parts..

## MAINTENANCE CHART

In order to maintain good performance, check and maintain the motorcycle at the intervals listed in the Maintenance chart.

The capital letters in the following chart represent:

I: Inspect, including troubleshooting, cleaning, adding lubricating oil, adding oil, repairing and replacement.

A: Adjustment C: Cleaning R: Replacement L: lubricating

Maintenance Period Maintenance Item	Time (hrs)													
	10	30	60	90	120	150	180	210	240	270	300	330	360	Before each ride
Lubricating oil	R			R			R			R			R	I
Air filter	Begin from 100hrs, clean every 100hrs, replace if necessary													
Spark plug	Begin from 100hrs, clean every 100hrs, replace if necessary													
Valve clearance	A			A			A			A			A	
Fuel strainer				R			R			R			R	
Brake system	I	I	I	I	I	I	I	I	I	I	I	I	I	I
Drive Chain	I/L			I/L			I/L			I/L			I/L	I
Fasteners	I/A			I/A			I/A			I/A			I/A	
<ul style="list-style-type: none"> <li>• <input type="checkbox"/> While the hours may exceed the maximum data in the chart, please maintain the maintenance procedures at the hour intervals listed.</li> <li>• <input type="checkbox"/> If riding in dusty or wet conditions, provide maintenance more frequently.</li> </ul>														

# MAINTENANCE

## Air Filter

The air cleaner element needs to be cleaned or replaced periodically (see chart for cleaning/replacement intervals). The air filter element will need to be cleaned more often if Mini Bike is ridden in muddy, wet, or dusty conditions. A clean air filter will help the Mini Bike run at peak performance allowing better gas mileage, more power and will protect the engine from the damaging effects of dirt entering the engine.

### Air filter removal, inspection and cleaning instructions

- 1, Locate the air filter assembly (1)
2. Remove the Air filter assembly cover by removing the air filter cover knob (2).
3. Remove the air filter element from the assembly by removing the wing nut (3)
3. Remove the foam element (4) from the paper air filter element (5) and clean foam element with mild soap and water. Rinse and squeeze out excess water and allow to dry . Note: If foam element (4) is damaged, replace.
4. Inspect the air filter paper element (5) for dirt and damage. If dirty, gently tap element on ground to remove any excess debris. Gently blow out element from the inside with compressed air. If element is too clogged or damaged for continued use, replace the element.

## CAUTION

Clean air filter frequently if Mini Bike is driven in wet, muddy or dusty conditions.

Driving in the above conditions without cleaning frequently can plug up the air filter which can cause poor gas mileage, low power and cause damage to the engine.

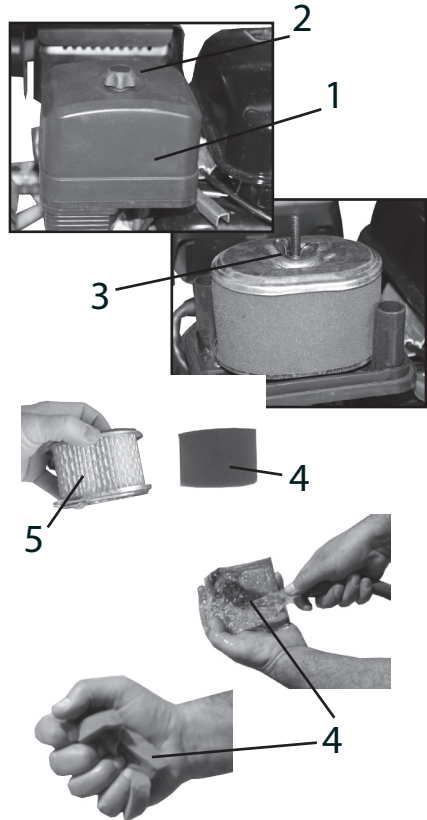

# MAINTENANCE

## Spark Plug

This Mini Bike comes equipped with a CHDY- F7TC spark plug.

To inspect the spark plug, remove the air filter cover and element to gain access. Remove spark plug cap (1) then remove the spark plug from the engine with the spark plug tool provided.

Inspect the plug for carbon deposits and clean if necessary. If plug shows excessive carbon, replace the plug.

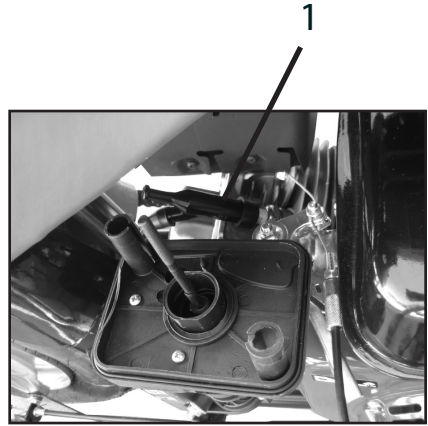

### CAUTION

Dirt can damage the engine if it enters the spark plug hole.

Make sure the spark plug hole is covered after removing plug.

Use a thickness feeler to inspect the spark plug gap (2). The spark plug gap should be 0.6 - 0.8mm (0.024 - 0.032 in.)

Re-install the inspected plug or new plug until finger tight. Finish tightening plug with a wrench. If the plug is a new plug, tighten approximately 1/2 turn more with the wrench. If plug is an old plug, tighten approximately 1/8 turn more with a wrench.

CHDY F7TC

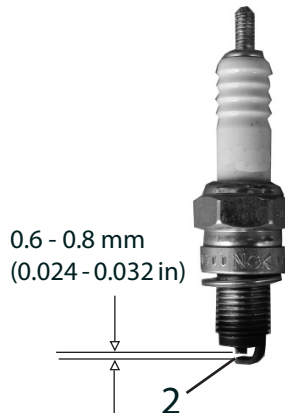

# MAINTENANCE

## Engine Oil

The proper amount and grade of engine oil will have a great impact on the life of the engine. Checking the oil daily and changing the oil as listed in the maintenance schedule is the most important maintenance procedure for the engine.

### Checking the engine oil

1. Make sure the Mini Bike is on level ground.
2. Check engine oil level by removing the oil fill plug/dipstick (1) located on bottom front left front side of the engine.
3. If engine oil is low, add oil until oil is at edge of fill hole (2). Use the correct grade of oil as listed in this manual. Do not over or under fill engine with oil, this could damage the engine.

### Changing the engine oil

1. Make sure engine is warm before attempting to drain the oil. A warm engine will help the oil drain quicker.
2. Remove the oil fill plug (1)
3. Remove the drain bolt (3) located on the bottom of the engine.
4. Allow the oil to drain in an appropriate container. Note: Dispose of oil at an oil recycle center.
5. Install the drain plug and fill with the appropriate type of oil as listed in this manual. This mini bike takes .63qt. (.6L) of engine oil.
6. Re-install fill cap, Start engine and allow to run for a few minutes, Re-check oil level and fill accordingly.

## ⚠ WARNING

New and used oil can be hazardous

Children and pets can be harmed by swallowing new or used oil. Continuous contact with used engine oil has been found to cause skin cancer in laboratory animals

Always keep new or used oil away from children and pets.

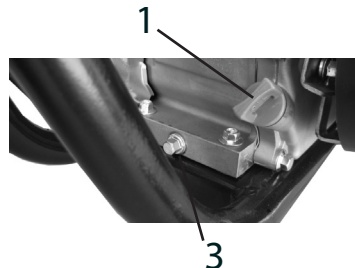
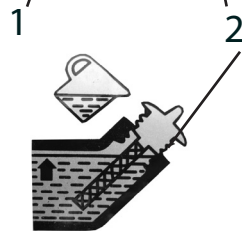



# MAINTENANCE

## Throttle Cable adjustment

It is important that the throttle grip have a certain amount of free play so the throttle does not rise when the handlebars are turned from left to right.

The hand grip throttle free play (2) should be .078 - .24 in (2-6 mm)

To adjust freeplay

1. Loosen jam nut (3)
2. Turn adjusting nut (4) to proper setting
3. Once throttle grip is at the proper freeplay, re-tighten the jam nut (3).

**NOTE:** After any adjustment, make sure throttle snaps back to idle when released.

## Fuel Hose Inspection

Inspect the fuel hose for any cracks or leaks and make sure all clamps are in place. Replace the fuel hose if any defects are found.



## **⚠ WARNING**

Inadequate throttle play can be hazardous

The engine speed could rise when the handlebars are turned if there is not enough throttle play. This could result in loss of control.

Always check throttle play before each ride. Turn handlebars from side to side making sure throttle does not increase when doing so.

# MAINTENANCE

## Brakes

### Brake Lever Adjustment

The front left brake lever (1) should have 2.0 - 4.0mm (0.08 - 0.16) of free play.

To adjust brake lever free play:

1. Loosen the Jam nut (2) on the brake cable.
2. Turn the adjuster nut (3) until the correct amount of free-play is achieved.

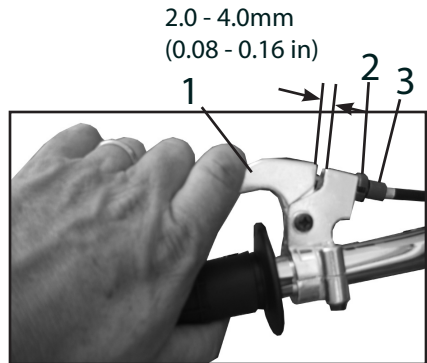

### Brake Adjustment

The brake adjustment nut (4) is located on the rear brake drum assembly (5) located on the rear wheel

To adjust brakes, turn the adjusting nut (4) clockwise to increase braking, counter clockwise to decrease braking.

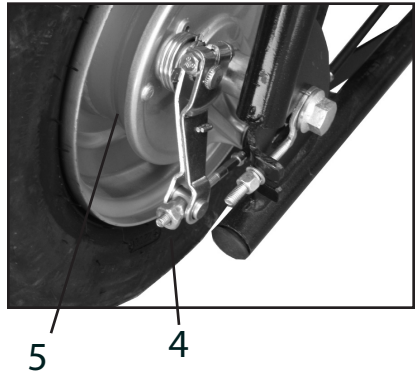

### Valve Clearance:

Adjusting the valves should be done by an authorized service center. Proper valve gap will help Mini Bike run at peak performance. Follow the valve gap adjustment intervals listed in the maintenance chart.

Proper Valve Clearance

Intake: 0.1 - 0.15 mm  
Exhaust: 0.15 - 0.2 mm

# MAINTENANCE

## Chain

### Chain and Sprocket Inspection

Inspect the drive chain for wear, rust, bound links, proper lubrication and proper tension.

If the drive chain has a problem correct or replace. Contact a service center for chain replacement.

A worn drive chain could also mean the sprockets may be worn.

Look for the following on the sprockets (1): Worn teeth, broken or damaged teeth, Loose sprocket mounting nuts.

If the sprocket shows signs of wear, contact a service center for replacement.

## Chain lubrication

Lubricating the chain before each ride will help to ensure maximum life of the chain and sprockets.

### Instructions for cleaning and chain lubrication:

1. Clean chain with a chain cleaner.
2. Lubricate chain with chain lube.

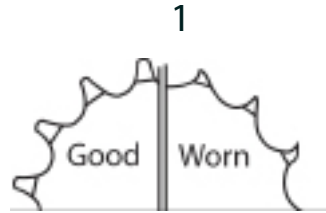

## Chain tension

Check the tension of the chain. The chain (1) tension should be 1/2 - 3/4 in. (15-20mm)

### Chain tension (slack) adjustment

1. Loosen bolts under engine (2) on the rear axle assembly.
2. Adjust chain tension by turning the tension nuts (3) (Note: tension nuts are located on both sides of the mini bike.) Clockwise will tighten the chain. Counter clockwise will loosen the chain.
3. Once the chain is at the correct tension re-tighten axle bolt (2).
4. Re-check chain tension.

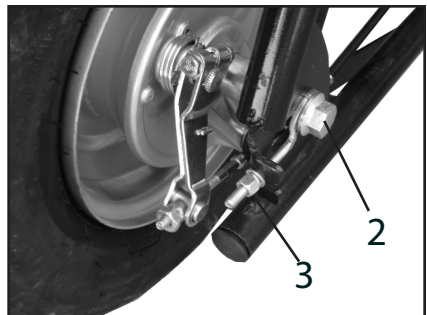
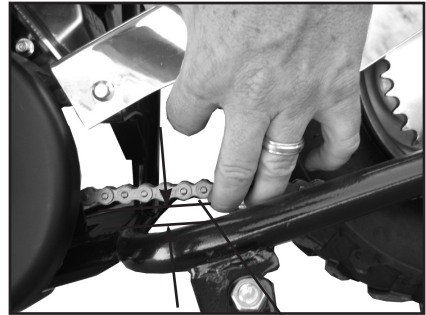

# MAINTENANCE

## Centrifugal Clutch Cleaning and lubrication

To help ensure the maximum life out of the Centrifugal clutch. It is important to clean and lubricate the clutch after every 5 hours of operation. To Clean and lubricate, follow the instructions below

1. Make sure engine is not running and that the engine and clutch has had time to cool.
2. Remove clutch cover (1).
3. Wipe off Centrifugal clutch (2) with a clean rag.
4. Lubricate Centrifugal clutch (2) using the same type of motor oil that is used in the engine. Place a few drops of motor oil on the drive shaft (3) where the clutch is attached. Do not oil any other portion of the clutch. DO NOT PLACE ANY OIL IN THE LARGE HOLES IN THE CLUTCH. THE HOLES ARE FOR AIR CIRCULATION ONLY. DO NOT OIL THE INSIDE OF THE CLUTCH.
5. RE-INSTALL THE CLUTCH COVER BEFORE STARTING OR OPERATING THE MINI BIKE.

Shut off engine and allow to cool before performing maintenance and inspection on the centrifugal clutch.

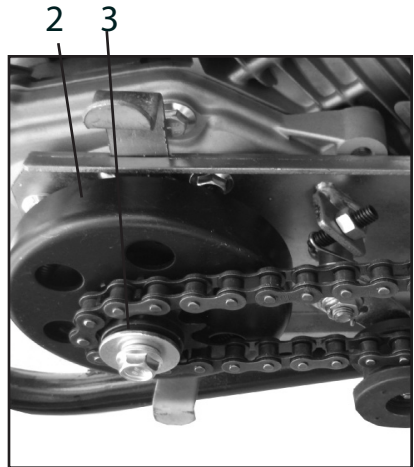
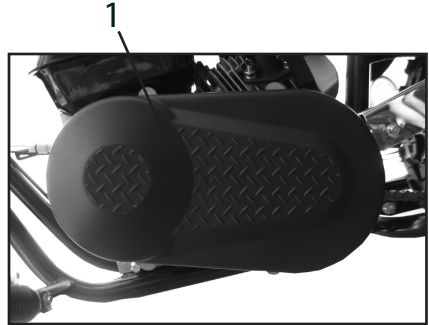

### ⚠️ WARNING

Performing maintenance and inspection on the centrifugal clutch while the engine is running could be hazardous.

Performing maintenance and inspections on the centrifugal clutch while the engine is running could result in getting body parts or clothing caught in moving parts, or could result in touching hot items which could result in severe injury.

### ⚠️ WARNING

Operating the mini bike without the clutch cover in place could be Hazardous.

Operating the mini bike without the clutch cover could result in getting body parts or loose clothing caught in moving parts which could result in severe injury.

Never Start or operate the mini bike without the clutch cover in place.

# MAINTENANCE

## Tires

Inspect tires before each ride, this should include the following:

1. Inspect for cracks or leaks
2. Inspect tread depth. If tread depth is below 4mm (.16 in.) replace the tire.
3. Check tire pressure. Incorrect tire pressure can affect the handling, rider comfort, steering, tire life and traction. Always check the tire pressure before each ride.

Tire pressure

Front tires: 10psi (69 kpa)

Rear tires: 10psi (69 kpa)

Tire size:

Front tires: AT19x7-8

Rear Tires: AT19x7-8

## Replacing tires

Always replace tires with type and size listed in this manual.

Always use the correct tools when replacing tires. The bead and sometimes the rim can be damaged by using the wrong type of tools. It is usually best to have tires replaced by an authorized service center. Service centers have the correct equipment and expertise to change tires without causing damage.

Punctures to tires can usually be repaired by using plug type patches. Plug type patches cannot repair tires that have been cut. If the tire has been cut or has a puncture in a location or size that cannot be repaired, replace the tire.

Be prepared for flat tires, always carry a plug type patch kit and air pump with you.



Minimum tread  
4mm (.16 in.)



## ⚠ WARNING

Operating this Mini Bike with worn tires could be hazardous

Operating this Mini Bike with worn tires will reduce traction which could result in an accident.

Never operate this Mini Bike with tires that have a tread depth of less than 4mm (0.16 in.)

## ⚠ WARNING

Operating this Mini Bike with improper tire sizes or pressure could be hazardous

Operating this Mini Bike with improper tire sizes or pressure could result in loss of control of the Mini Bike which could result in an accident.

Never operate this Mini Bike with improper tire sizes or pressure.

## Storage

If the Mini Bike is left unused for an extended period of time proper storage maintenance is required.

1. Wash Mini Bike thoroughly, then wax painted parts with a non abrasive auto wax. Coat vinyl seat and rubber parts with a vinyl/rubber protectant.

Note: Keep water away from air intake and muffler outlet while washing to avoid water from entering the engine and/or components.

2. Drain carburetor by placing fuel valve (1) to the off (right) position and opening the drain screw (2). Allow all fuel to drain from the carburetor. Once fuel is drained, re-tighten drain screw (2). Note: Make sure to drain fuel in a proper storage container.

3. Fill fuel tank to full with gasoline mixed with fuel stabilizer as recommended by the fuel stabilizer manufacture. Note: Fuel stabilizer can be purchased at most motorcycle shops and auto parts stores.

4. Remove spark plug and pour 1 tablespoon of motor oil in the spark plug hole. Re-install spark plug.

5. Place the starter button to the off position and pull the start recoil cord a few times. This is to coat the inside cylinder head with oil.

6. Fill tires with correct air pressure.

7. If possible, store Mini Bike in a shed or garage with a cover to protect from dust, dirt and humidity. If the Mini Bike must be stored outdoors, cover completely with a good waterproof cover.

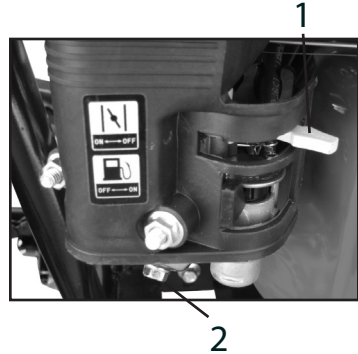

## Returning to service

1. Wash Mini Bike thoroughly.

Note: Keep water away from air intake and muffler outlet while washing to avoid water from entering the engine and/or components.

2. Drain engine oil and replace with fresh clean oil as listed in this manual.

3. Review this owner's manual and follow the pre-ride inspection procedures.

4. Start engine by following the starting procedures in this manual.

## Washing the Mini Bike

1. Wash mud and dirt off Mini Bike with low pressure water from a hose. Do not use high pressure nozzles, this could allow water to enter the engine causing damage.

2. Wash Mini Bike using a mild detergent or car soap using a sponge, soft rag or brush. Do not use any cleaning materials that could scratch the surfaces.

Note: Be careful not to allow water to enter the muffler outlet, air filter intake, brake cable, throttle cable or switches.

## Transporting

1. Make sure fuel valve (1) is turned to the OFF (left) position.

2. Drain carburetor by turning fuel valve (1) to the off position and opening the drain screw (2). Allow all fuel to drain from the carburetor. Once fuel is drained, re-tighten drain screw (2).

Note: Make sure to drain fuel in a proper storage container.

3. Transport the Mini Bike with the Mini Bike in the upright position (3) tied down securely.

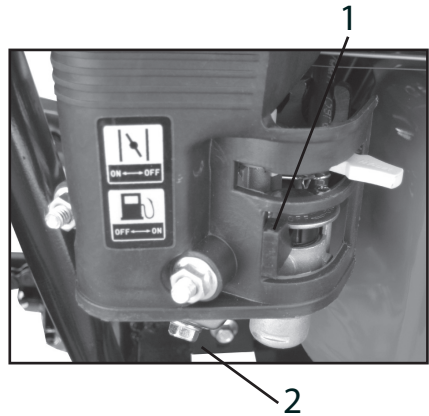

3

# TROUBLESHOOTING

Trouble	Possible cause	Solution
Engine will not start	<ul style="list-style-type: none"> <li>• Low fuel</li> <li>• Stale or contaminated fuel.</li> <li>• Fuel valve is in the "OFF" position</li> <li>• Loose spark plug</li> <li>• Spark plug fouled or defective.</li> <li>• Spark plug gap is incorrect</li> <li>• Spark plug cap is not attached</li> <li>• Choke is not in the "ON" (left) position for starting a cold engine.</li> <li>• Problem with the electrical system</li> <li>• Air filter dirty</li> <li>• Valves not adjusted properly</li> </ul>	<ul style="list-style-type: none"> <li>• Fill with fresh fuel</li> <li>• Have a service center flush and fill with fresh fuel.</li> <li>• Place fuel valve in the "ON" position.</li> <li>• Tighten spark plug</li> <li>• Clean or replace plug.</li> <li>• Gap the plug</li> <li>• Attach spark plug cap</li> <li>• Place choke in the "ON" (left) position</li> <li>• Take to a service center for repair</li> <li>• Clean or replace air filter</li> <li>• Take to a service center for repair</li> </ul>
Engine stalls or runs erratically	<ul style="list-style-type: none"> <li>• Low fuel</li> <li>• Stale or contaminated fuel</li> <li>• Choke is left in the "ON" (left) position</li> <li>• Spark plug is fouled or defective</li> <li>• Spark plug gap is incorrect</li> <li>• Spark plug cap is loose</li> <li>• Carburetor is clogged or has water in it</li> <li>• Idle is not adjusted properly</li> <li>• Problem with the electrical system</li> <li>• Air filter dirty</li> <li>• Valves not adjusted properly</li> </ul>	<ul style="list-style-type: none"> <li>• Fill with fresh fuel</li> <li>• Have a service center flush and fill with fresh fuel.</li> <li>• Place the Choke in the "OFF" (right) position.</li> <li>• Clean or replace plug</li> <li>• Gap the plug</li> <li>• Secure the spark plug cap</li> <li>• Take to a service center</li> <li>• Take to a service center</li> <li>• Take to a service center for repair</li> <li>• Clean or replace air filter</li> <li>• Take to a service center for repair</li> </ul>



# SPECIFICATIONS

## Engine

Displacement 196cc  
Starting Recoil Cord  
Spark Plug Typ CHDY - F7TC  
Cooling Air cooled  
Ignition Type T.C.I  
Cylinder head config. OHV  
Number of Cylinder Single  
Combustion Cycle 4-stroke  
Bore and Stroke 68x54mm  
Compression Ratio 8.5:1  
Carburetor KERUIDI  
Rated Power 3.8kw @ 3600rpm  
Rated Torque 11Nm @ 2500rpm  
Speed 20mph(32km/h)

## Transmission

Drive System Type Chain Drive  
Gear Ratio 10:1  
Centrifugal Clutch

## Suspension

Front Type Low pressure tires  
Rear Type Low pressure tires

## Braking

Rear Brakes (Type) Drum

## Tires

Front Tire Size AT19x7-8  
Rear Tire Size AT19x7-8

## Dimensions and Weights

Length 57in (1450mm)  
Height 26.5in. (680mm)  
Width 38in. (960mm)  
Wheelbase 42in. (1050mm)  
Vehicle Wt. 121lbs (55 Kg)  
Weight Cap. 200lbs (91kg)  
Ground Clearance 6.5"(165mm)

## Fuel

Gas Tank Capacity .95gal.  
(3.6L)  
Fuel type Unleaded Gasoline  
90 Octane or higher

## Oil

Oil Capacity .63qt. (.6L)  
Oil Type SAE 10W-30

# FRAME AND ENGINE NUMBER LOCATION

VIN #

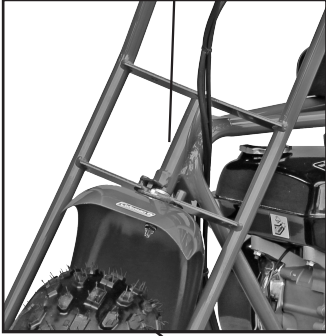

The Vehicle identification number and the engine number are needed when calling for parts, service center help or when registering your Mini Bike. Locate the numbers and list the numbers below for reference.

The 17 digit Vehicle Identification Number (VIN) is located on the vertical tube on the neck of the mini bike

Vehicle Identification Number

--	--	--	--	--	--	--	--	--	--	--	--	--	--	--	--	--	--

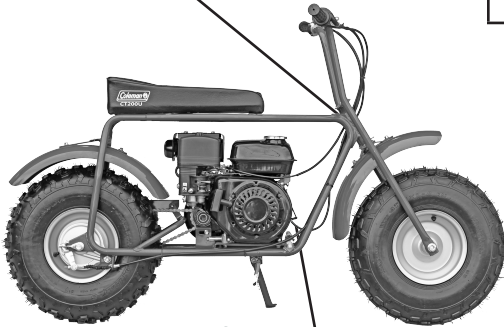

ENGINE #

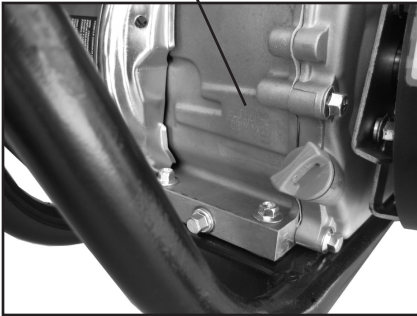

The engine number is located on the left, bottom front portion of the Mini Bike Engine.

EngineNumber



59 9 44 1 15

M 15

d 15

15

15

A R

1

4

5

**A** 选项，根据上下文，作者主要是在讨论某种理论或方法的有效性。作者提到，这种理论或方法在许多情况下都能得到验证，但在某些特殊情况下可能会遇到挑战。作者通过对这些挑战的分析，进一步证实了该理论或方法的普遍适用性。作者还提到，这种理论或方法在实际应用中也得到了广泛的支持和认可。

□

作者指出，尽管存在一些挑战，但这些挑战并没有动摇该理论或方法的根基。相反，它们为理论的进一步完善提供了宝贵的参考。作者还提到，该理论或方法在解决实际问题时表现出了强大的生命力和适应性。作者通过对这些问题的深入探讨，进一步巩固了该理论或方法的科学性和实用性。

□

作者认为，该理论或方法的成功，主要得益于其科学性和实用性。作者通过对这些方面的深入探讨，进一步证实了该理论或方法的科学性和实用性。

**A** 选项，根据上下文，作者主要是在讨论某种理论或方法的有效性。作者提到，这种理论或方法在许多情况下都能得到验证，但在某些特殊情况下可能会遇到挑战。作者通过对这些挑战的分析，进一步证实了该理论或方法的普遍适用性。作者还提到，这种理论或方法在实际应用中也得到了广泛的支持和认可。

作者指出，尽管存在一些挑战，但这些挑战并没有动摇该理论或方法的根基。相反，它们为理论的进一步完善提供了宝贵的参考。作者还提到，该理论或方法在解决实际问题时表现出了强大的生命力和适应性。作者通过对这些问题的深入探讨，进一步巩固了该理论或方法的科学性和实用性。

**ADD** 选项，根据上下文，作者主要是在讨论某种理论或方法的有效性。作者提到，这种理论或方法在许多情况下都能得到验证，但在某些特殊情况下可能会遇到挑战。作者通过对这些挑战的分析，进一步证实了该理论或方法的普遍适用性。作者还提到，这种理论或方法在实际应用中也得到了广泛的支持和认可。

作者指出，尽管存在一些挑战，但这些挑战并没有动摇该理论或方法的根基。相反，它们为理论的进一步完善提供了宝贵的参考。作者还提到，该理论或方法在解决实际问题时表现出了强大的生命力和适应性。作者通过对这些问题的深入探讨，进一步巩固了该理论或方法的科学性和实用性。

□

□

□ □ □ □ **M** □ □ **r** □ □ □ **r** □ □ □ □ □ **A** □

□ 1 □ □ □ □ □ □ □ □ **r** □ □ □ □ **Dr** □ □ □

**M** □ □ □ □ □ □ □ □ □ □ □ □ 5 □ □ 9 □

□ □ □ □ □ □ 9 □ □ 44 □ □ □ □ □ □ □

□ □ □ □ 9 □ □ 44 □ □ □ □ □ 5 □

□ □ □ □ **r** □ □ □ □ □ □ □ □ □ □ □ □ 1 □ □



# POWERSPORTS

1775 E. University DR.  
Tempe, AZ. 85281

**PHONE: Toll Free 888-405-8725**

<https://www.colemanpowered.com>

<https://www.facebook.com/Colemanpowersportusa>

[https://www.instagram.com/colemanpowersports\\_usa](https://www.instagram.com/colemanpowersports_usa)